





Bestellen unter:

 (0 71 51) 7 26 26

 Fax (0 71 51) 7 42 01

 [info@maku-industrie.de](mailto:info@maku-industrie.de)

 [www.maku-industrie.de](http://www.maku-industrie.de)

Beratung unter:

 (0 71 51) 7 26 26

# *Pneumatic Quick Couplings*



## Pneumatic Quick Couplings

### Single Shut-Off Couplings

Single Shut-Off couplings are primarily used for pneumatic applications, connecting air tools, hoses, or other implements to compressed air supplies. They are also used with other gases, and with the exception of the E-z-mate Series can be used with low pressure fluids. The coupler half contains a shut-off valve that is automatically opened when a mating nipple is inserted and automatically closes when the nipple is removed.

Parker Single Shut-Off couplings come in three basic designs: general purpose/manual connect, general purpose/push-to-connect, and special purpose.

The standard seal material for all Parker Single Shut-Off couplers is Nitrile. Ethylene Propylene, Fluorocarbon, and Neoprene seals are available as options. See the comprehensive Fluid Compatibility Chart that provides guidelines for seal and body material selection. When there is need for further assistance in selecting the appropriate seal material, please consult factory.

### General Ordering Information

When ordering Parker coupler bodies and nipples, please state the part number of each type of coupler body and each type of nipple desired. List coupler bodies and nipples as separate items rather than in combinations. Be sure to double check thread or hose sizes of items required.

Many of Parker's coupling products are available with unique non-standard options well suited to very specific applications. Examples of unusual end use applications might include: high temperatures (above 250° F), extremely caustic/corrosive solutions passing through the coupling, external/environmental corrosion situations, or other high wear and tear situations such as dragging the product along

the ground. It is always recommended that the Quick Coupling Division be contacted with any questions concerning specific product application needs.

Typically, a prefix or suffix is added to the base part number to specify a non-standard O-ring seal, or special option such as a sleeve lock. The list at right illustrates the designations.

Please Note: Certain couplings series have additional "Special Order Information" which should be referred to in ordering those products. If applicable to the product, "Special Order Information" is found next to the Features and Specifications charts. See the Coupling Selection and Ordering Guide for further information.

#### Checklist for Selecting Quick Couplings

- What are the functional requirements of the coupling?
- What is the maximum working pressure of the application?
- Which seals and body material are compatible with the system's fluid?
- Is the application static or dynamic?
- What size coupler is required?
- What is the maximum pressure drop suitable for the application?
- Does the application require the ability to connect and disconnect under pressure?
- What is the media temperature and ambient temperature?
- What end configurations are required?
- Is an industry interchange coupler required?
- Is air inclusion and fluid loss a concern in the application?



<b>Introduction .....</b>	<b>A-2</b>	<b>30 Series .....</b>	<b>A-27 to A-30</b>
<b>Coupling Selection &amp; Ordering Guide.....</b>	<b>A-4</b>	Couplers .....	A-29 to A-30
<b>Interchange Match-up Chart.....</b>	<b>A-5</b>	<b>Twist-Lock Couplings .....</b>	<b>A-31</b>
<b>Industrial Interchange Nipples .....</b>	<b>A-6 to A-7</b>	Couplers .....	A-32
<b>General Purpose Couplings</b>		Nipples.....	A-32
<b>Manual Connect.....</b>	<b>A-8</b>	<b>Special Purpose Couplings</b>	
10 Series.....	A-9	<b>Standard - Non Marring Composite .....</b>	<b>A-33</b>
Couplers .....	A-10	Tool-Mate Series Couplers .....	A-34
Nipples.....	A-11	<b>Exhaust - Non Marring Composite .....</b>	<b>A-35</b>
20 Series.....	A-12	Tool-Mate Series Couplers .....	A-36
Couplers .....	A-13	<b>Exhaust - Steel.....</b>	<b>A-37</b>
50 Series.....	A-14	E-z-mate Series .....	A-37
Couplers .....	A-14	Couplers .....	A-38
Nipples.....	A-15	<b>Accessories</b>	
70 Series.....	A-16	Blow Guns	
Couplers .....	A-16	Controlled Pressure .....	A-39
Nipples.....	A-16	Full Pressure .....	A-39
<b>Push-to-Connect.....</b>	<b>A-17</b>	BG Series .....	A-40
RF Series .....	A-18	Two-Way Valves .....	A-41
Couplers .....	A-19		
Nipples.....	A-20		
Tool-Mate Series .....	See pages A-33 to A-36		
HF Series .....	A-21		
Couplers – 1/8" .....	A-22		
Nipples – 1/8" .....	A-22		
Couplers – 1/4", 3/8" & 1/2".....	A-23		
HF Series Heavy Duty Couplers – 1/4" & 3/8" .....	A-24		
HA Series.....	A-25		
Couplers .....	A-25		
Nipples.....	A-15		
Universal Coupler .....	A-26		
Couplers .....	A-26		

## Pneumatic Quick Couplings

	Coupler Style	Interchange	Body Size (in.)	Material*				Locking Mechanism	Std. Seal** Material	Std. Seal** Temp Range	Rated Pressure
				B	SS	S	P				
<b>General Purpose – Manual Connect</b>											
10 Series	Manual	Tru-Flate	1/4 to 1/2	●		●		Ball	Nitrile	-40° to +250° F	300 PSI
20 Series <sup>1</sup>	Manual	Industrial	1/4 to 1/2	●	●	●		Ball	Nitrile	-40° to +250° F	300 PSI
50 Series	Manual	ARO 210	1/4	●		●		Ball	Nitrile	-40° to +250° F	300 PSI
70 Series	Manual	Lincoln (long stem)	1/4	●				Ball	Nitrile	-40° to +250° F	300 PSI
<b>General Purpose – Push-To-Connect</b>											
RF Series	Push to Connect	CEJN 320/410 Rectus 25/27	1/4 & 3/8	●		●		Ball	Nitrile	-40° to +250° F	300 PSI
HF Series	Push to Connect	Industrial	1/8 <sup>2</sup> to 1/2	●		●		Ball	Nitrile	-40° to +250° F	300 PSI
30 Series	Push to Connect	Industrial	1/4 to 3/4	●				Pawl	Nitrile	-40° to +250° F	300 PSI
HA Series	Push to Connect	ARO 210	1/4	●				Ball	Nitrile	-40° to +250° F	300 PSI
Twist Lock	Push to Connect	Schrader	1/4 to 1/2	●		●		Cam	Nitrile	-40° to +250° F	300 PSI
Universal	Push to Connect	Industrial Tru-Flate ARO 210	1/4	●				Ball	Nitrile	-40° to +250° F	150 PSI
<b>Special Purpose – Push-To-Connect</b>											
E-z-mate Series	Exhaust/ Push to Connect	Industrial	1/4 to 3/4			●		Ball	Nitrile	-40° to +250° F	300 PSI
Tool-Mate Series	Push to Connect/ Exhaust & Std	Industrial & CEJN 320 / Rectus 25	1/4 to 1/2			● <sup>3</sup>	●	Fingers	Nitrile	-40° to +250° F	300 PSI

<sup>1</sup> 20 Series Stainless Steel available in 1/4" body.

<sup>2</sup> 1/8" couplings have no standard industry interface.

<sup>3</sup> Tool-Mate metal end ports are Galvanized Steel.

**\* Material Code:**

B = Brass; SS = Stainless Steel; S = Steel; P = Plastic

**Coupling Material****Coupler**

- Prefix "B" for Brass - available for 3/8 & 1/2" body sizes only
- Suffix "N" for Stainless Steel springs, locking balls and brass valves. (10, 20, 30, 50, and 70 series only)

**Nipple**

- Prefix "B" for Brass (Standard material is steel)

**\*\* Optional Seals**

Material	Suffix	TEMP Range
Ethylene Propylene	W	-65° to +400° F
Fluorocarbon	Y	-30° to +400° F

To select proper seal materials, see Fluid Compatibility Chart in Appendices section, or contact your Parker Quick Coupling Distributor.

## Interchange Match-up Chart

### Pneumatic Quick Couplings

#### Popular Coupling Designs

Parker's Quick Coupling Division manufactures quick couplings to interchange with popular designs that have become accepted standards in the industry today. The actual

size nipple chart below can be used to help select Parker Quick Couplings that will interchange with specific nipple designs and sizes.

#### 10 Series (Tru-Flate Interchange)

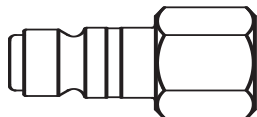

1/4" Body Size

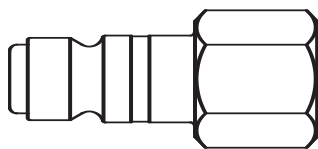

3/8" Body Size

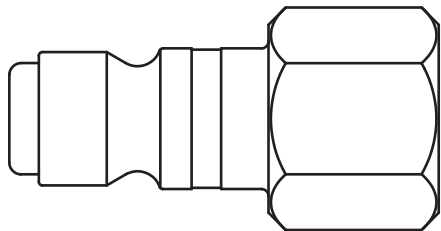

1/2" Body Size

#### Twist-Lock (Schrader Interchange)

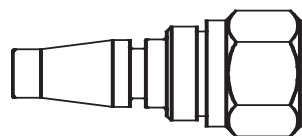

1/4" Body Size

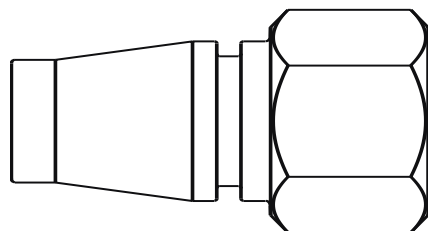

1/2" Body Size

#### 20 Series, 30 Series, HF Series, E-z-mate (Industrial Interchange)

##### 1/8" HF Series

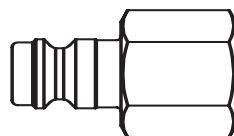

1/8" Body Size

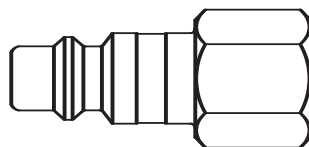

1/4" Body Size

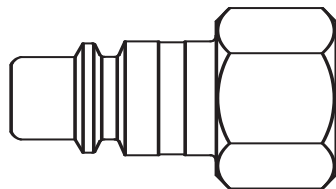

3/8" Body Size

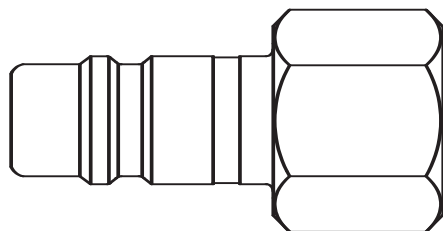

1/2" Body Size

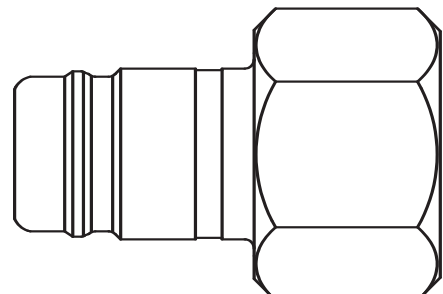

3/4" Body Size

#### 50 Series (ARO-210 Interchange)

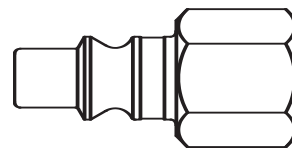

1/4" Body Size

#### 70 Series (Lincoln Interchange)

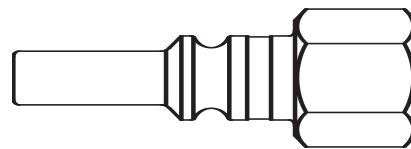

1/4" Body Size

#### RF Series

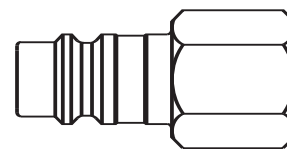

1/4" Body Size

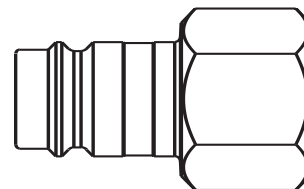

3/8" Body Size

**Pneumatic Quick Couplings**



**Features**

- Parker Industrial Interchange nipples are for use with any Parker 20 Series, HF Series, 30 Series, Universal, HF or E-z-mate couplers.
- Parker Industrial Interchange nipples are interchangeable with similar nipples manufactured by other quick coupling manufacturers conforming to A-A-59439 (formerly known as MIL-C-4109F), ANSI/(NFPA) T3.20.14-1990, or ISO6150-B requirements.
- Hardened wear points\*\* and solid barstock construction provide extended service life.
- Precision machined surfaces and hardened load-bearing areas\*\* resist the effects of mechanical shock in the most rugged applications.
- The 20 Series, HF Series, 30 Series, Universal and E-z-mate couplers that mate with the Industrial Interchange nipples are located in their respective coupling "Type" (e.g. Manual Type) as noted in the Table of Contents.

\*\* steel nipples only

**Female Pipe Thread**

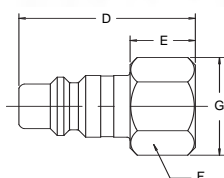

Body Size (in.)	Part No. Brass	Part No. Steel	Part No. Type 303 Stainless	Thread Size NPTF	Overall Length	Dimensions (in.)				Wt. (LB.) P/Piece	
						Exposed Length*	Hex Size	Largest Diameter			
						D	E	F	G		
1/4	-	H1C	-	1/8-27	1.48	0.71	0.50	0.58	0.03		
1/4	BH3C	H3C	SH3C	1/4-18	1.56	0.80	0.62	0.72	0.05		
1/4	-	H3C-E	SH3C-E	3/8-18	1.60	0.83	0.81	0.94	0.08		
3/8	-	H1E	-	1/4-18	1.60	0.69	0.62	0.72	0.06		
3/8	BH3E	H3E	-	3/8-18	1.69	0.74	0.81	0.94	0.10		
3/8	-	H3E-F	-	1/2-14	1.84	0.90	1.00	1.16	0.13		
1/2	-	H1F	-	3/8-18	2.03	0.79	0.81	0.94	0.12		
1/2	BH3F	H3F	-	1/2-14	2.20	0.96	1.00	1.16	0.19		
1/2	-	H3F-G	-	3/4-14	2.30	1.05	1.25	1.44	0.26		
3/4	-	H3G-F	-	1/2-14	2.22	1.06	1.00	1.16	0.23		
3/4	-	H3G	-	3/4-14	2.18	1.02	1.25	1.44	0.34		
3/4	-	H3G-J	-	1-11 1/2	2.41	1.25	1.63	1.80	0.47		

\*This dimension represents portion of nipple that is exposed when nipple is inserted in a Parker 20 Series coupler.



Pneumatic Quick Couplings

Male Pipe Thread

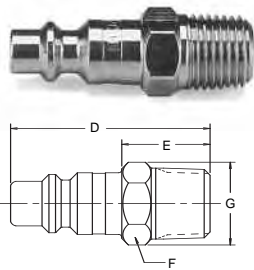

Body Size (in.)	Part No. Brass	Part No. Steel	Part No. Type 303 Stainless	Thread Size NPTF	Dimensions (in.)				Wt. (LB.) P/Piece
					Overall Length	Exposed Length*	Hex Size	Largest Diameter	
					D	E	F	G	
1/4	—	H0C	—	1/8-27	1.68	0.92	0.50	0.58	0.05
1/4	BH2C	H2C	SH2C	1/4-18	1.66	0.89	0.56	0.65	0.06
1/4	—	H2C-E	SH2C-E	3/8-18	1.90	1.14	0.69	0.80	0.07
3/8	—	H00E	—	1/8-27	1.68	0.73	0.62	0.72	0.08
3/8	—	H0E	—	1/4-18	1.90	0.95	0.62	0.72	0.08
3/8	BH2E	H2E	—	3/8-18	1.90	0.95	0.69	0.80	0.09
3/8	—	H2E-F	—	1/2-14	2.03	1.09	0.88	1.02	0.15
1/2	—	H0F	—	3/8-18	2.20	0.96	0.69	0.79	0.16
1/2	BH2F	H2F	—	1/2-14	2.35	1.09	0.88	1.01	0.18
1/2	—	H2F-G	—	3/4-14	2.40	1.16	1.06	1.22	0.24
3/4	—	H2G-F	—	1/2-14	2.32	1.16	1.00	1.16	0.22
3/4	BH2G	H2G	—	3/4-14	2.28	1.12	1.06	1.22	0.28
3/4	—	H2G-J	—	1-11 1/2	2.56	1.40	1.31	1.52	0.36

\*This dimension represents portion of nipple that is exposed when nipple is inserted in a Parker 20 Series coupler.

Standard Hose Barb

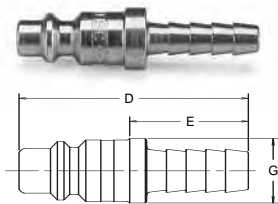

Body Size (in.)	Part No. Brass	Part No. Steel	Part No. Type 303 Stainless	Hose I.D.	Dimension (in.)			Wt. (LB.) P/Piece
					Overall Length	Exposed Length*	Largest Diameter	
					D	E	G	
1/4	—	H8C	—	1/4	1.72	0.95	0.46	0.04
1/4	—	—	SH8C	1/4	2.09	1.33	0.55	0.04
1/4	—	H8C-D	—	5/16	1.96	1.20	0.50	0.04
1/4	—	H9C	SH9C	3/8	1.96	1.20	0.50	0.05
3/8	—	H5E	—	3/8	1.85	.090	0.59	0.07
3/8	—	H6E	—	1/2	2.09	1.14	0.68	0.08
1/2	—	H4F	—	3/8	2.36	1.12	0.66	0.10
1/2	—	H5F	—	1/2	2.36	1.12	0.66	0.11
1/2	—	H5F-G	—	3/4	2.95	1.71	0.87	0.18
3/4	—	H5G-F	—	1/2	2.47	1.31	0.93	0.19
3/4	BH5G	H5G	—	3/4	3.00	1.84	0.93	0.25
3/4	—	H5G-J	—	1	3.24	2.08	1.24	0.36

\* This dimension represents portion of nipple that is exposed when nipple is inserted in a Parker 20 Series coupler.

Push-Lok Hose Barb\*\*

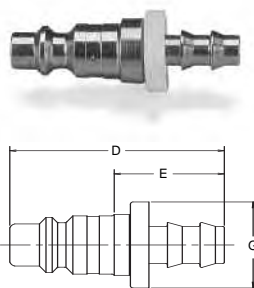

Body Size (in.)	Part No. Brass	Part No. Steel	Hose I.D.	Dimension (in.)			Wt. (LB.) P/Piece	
				Overall Length	Exposed Length*	Largest Diameter		
				D	E	G		
1/4	BH8CP	H8CP	—	1/4	1.74	0.97	0.69	0.04
1/4	—	H9CP	—	3/8	1.96	1.19	0.86	0.05
3/8	—	H4EP	—	1/4	1.87	0.92	0.69	0.06
3/8	—	H5EP	—	3/8	2.02	1.07	0.86	0.07
3/8	—	H6EP	—	1/2	2.21	1.27	0.97	0.09
1/2	—	H4FP	—	3/8	2.36	1.11	0.86	0.11
1/2	—	H5FP	—	1/2	2.48	1.24	0.97	0.11
1/2	—	H6FP	—	5/8	2.95	1.71	1.14	0.14

\*This dimension represents portion of nipple that is exposed when nipple is inserted in a Parker 20 Series coupler.

\*\*Push-Lok hose barbs are designed for use with Parker push-lok hose and do not require clamps.



## Pneumatic Quick Couplings

### General Purpose – Manual Connect

10 Series, 20 Series, 50 Series, 70 Series

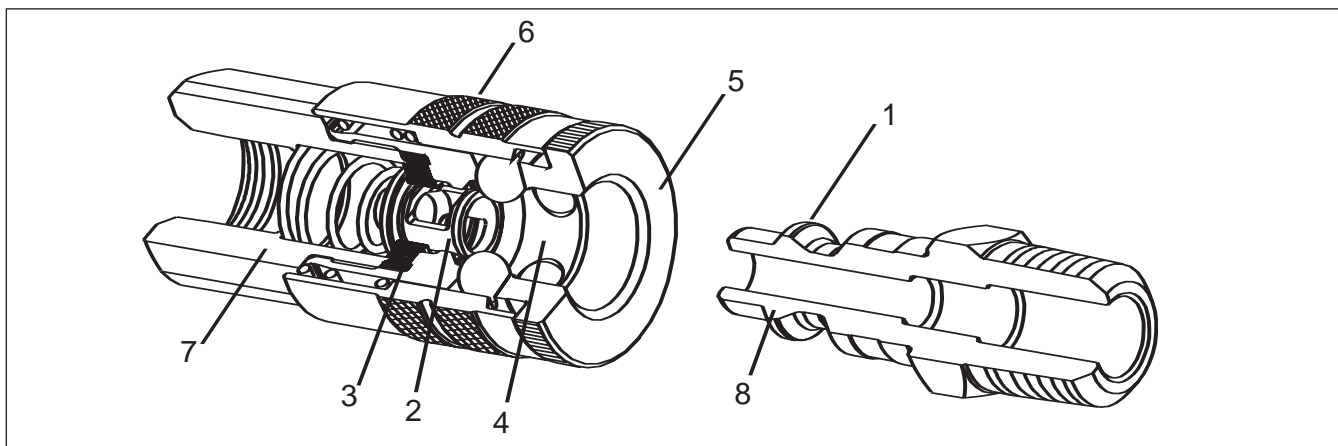

#### Component Part Features for Manual Couplers, Series 10, 20, 50 & 70 Series

1. Precision machining, hardened wear points\* and solid barstock construction provide long life even in rugged applications.
2. Tubular valve with large flow passages delivers high air flow with minimal pressure drop for efficient performance. The tubular design provides 360° support for both the valve seal and the mating nipple for long service life.
3. Precision molded seals form a “bubble tight” seal for reliable operation within rated working pressures. Standard seal material is Nitrile. Ethylene Propylene, Fluorocarbon and Neoprene seals are available as options.
4. Proven ball locking mechanism with large numbers of hardened steel or stainless steel locking balls evenly distribute the load to resist wear and provide positive connections. The ball locking mechanism also provides accurate alignment and allows a swiveling action to reduce hose torque.
5. Integral sleeve guard protects the sleeve and resists accidental disconnects by allowing the coupling to ride over obstructions without the sleeve being retracted.
6. Knurling and/or grooves on sleeve provide a gripping surface for ease of operation.
7. Wide range of body sizes, materials, options and end terminations are available to meet specific needs. Parker sleeve type couplings are available with male pipe thread, female pipe thread, standard hose barb, Push-Lok hose barb\*\*, and reusable hose fitting ends. Standard body materials are brass in 1/4" body size and steel in larger sizes.
8. Parker sleeve type couplings are available in interchanges for industrial interchange, Tru-flate, ARO 210 and Lincoln long stem design nipples.

\* Steel nipples only.

\*\* Push-lok hose barbs are designed for use with Parker Push-lok hose and do not require clamps.

#### Accessories - Coupler Options

##### Grip-Ring Sleeve - Features

- This Grip-Ring sleeve enables the operator to connect or disconnect the coupling easily, even with greasy hands or while wearing heavy gloves.



- Grip-Ring sleeves are available for all 10 and 20 Series couplers (only). **To specify a model with a Grip-Ring sleeve, add the suffix letter “R” to the regular model number. Example: B13R.**

**Caution:** The Grip-Ring sleeve is subject to unintended disconnect if dragged on the end of a hose. Do not attempt to pull it over obstacles.

##### Sleeve-Lok - Features

- All sizes of 10, 20, 30, 50, and 70 Series couplers (only) can be furnished with Locking Sleeves, as illustrated.



- Place suffix letters -“SL” (Sleeve-Lok) after regular catalog number. Example: B13-SL.

#### Coupler Repair Kits for 10, 20, 30, 50, 70, & TL Series

Body Size	Seal Material	Part No.
1/4	Nitrile	21K
1/4	Ethylene Propylene	21KW
1/4	Fluorocarbon	21KY
3/8	Nitrile	14K
3/8	Ethylene Propylene	14KW
3/8	Fluorocarbon	14KY
1/2	Nitrile	16K
1/2	Ethylene Propylene	16KW
1/2	Fluorocarbon	16KY
3/4	Nitrile	38K
3/4	Ethylene Propylene	38KW
3/4	Fluorocarbon	38KY

## Pneumatic Quick Couplings

## General Purpose – Manual Connect

10 Series



### Features

- Parker 10 Series couplings are the original Tru-Flate design.
- This unique design has been field proven as a long lasting, high performance coupling especially when used with pneumatic tools.
- Standard seals are Nitrile. See the Coupling Selection and Ordering Information Guide at the beginning of Section A and the Fluid Compatibility Chart at the end of this catalog for optional materials.

### Specifications

Body Size (in.)	1/4	3/8	1/2
Rated Pressure (PSI)	300	300	300
Temperature Range (Std. seals)*	-40° to +250° F.		
Locking Device	4 balls	8 balls	8 balls
Vacuum Data (inches Hg)	<b>Not recommended</b>		
Disconnected (coupler only)	<b>Not recommended</b>		
Connected	27.4	27.4	27.4

\* See Coupling Selection and Ordering Guide for Optional Seals  
See **Coupling Repair Kits** Table on introduction page to General Purpose - Manual Connect Couplers.

### Applications

Sleeve type couplings are widely used to connect air lines and can also be used with low pressure fluids.

Their compact and economical design uses a ball locking mechanism consisting of captive steel balls that engage the locking groove on the mating nipple. The sliding spring loaded sleeve on the coupler must be manually retracted in order to connect or disconnect the nipple. It is easy to do, but two hands are normally required.

Common applications include: compressed air, water, grease, paint, limited vacuum and limited gases.

### How to Order Information

The standard 1/4" 10 Series features a brass coupler with a steel valve. Larger sizes include an all steel construction with brass also available. To order a 3/8" or 1/2" coupler with a brass body and steel sleeve, add the prefix "B" to the steel part number, Example: B15.

Add the suffix "N" as well as the "B" prefix to order an all brass coupler with stainless steel locking balls and springs, Example: B15N.

All-brass couplings should be used to avoid corrosion from moisture. Consult factory for specific recommendations.

Available with Sleeve-Lok (See Coupler Options). To order, add the suffix "SL" to the part number, Example: 15-SL.

Available for 1/4" 10 Series couplers is a Grip-Ring Sleeve (See Coupler Options). To order add the suffix "R" to the part number, Example: B13R.

### Performance

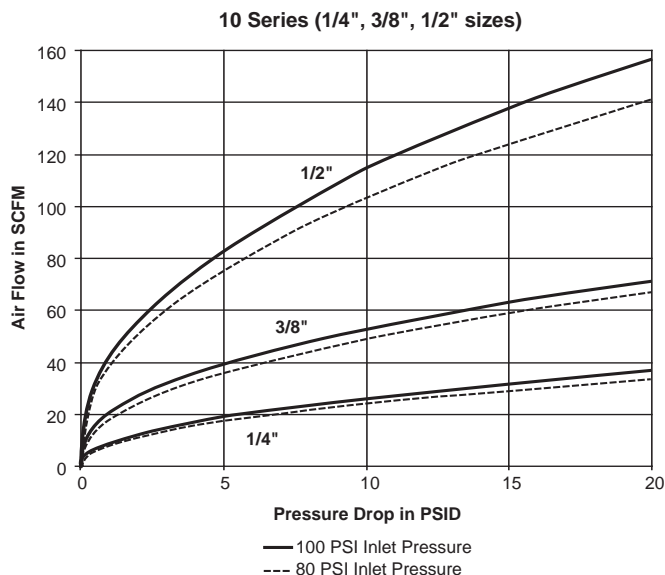

## Pneumatic Quick Couplings

### General Purpose – Manual Connect

10 Series

#### Couplers

##### Female Pipe Thread

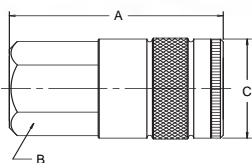
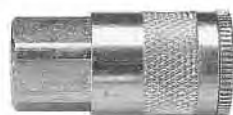

Body Size (in.)	Part No. Brass	Part No. Steel	Thread Size NPTF	Dimensions (in.)			Wt. (LB) P/Piece
				Overall Length	Hex Size	Largest Diameter	
				A	B	C	
1/4	B13A	–	1/8-27	1.83	0.75	0.90	0.19
1/4	B13	–	1/4-18	1.83	0.75	0.90	0.19
1/4	B13E	–	3/8-18	1.95	0.81	0.94	0.31
3/8	–	15C	1/4-18	2.22	0.88	1.06	0.30
3/8	B15	15	3/8-18	2.28	0.88	1.06	0.34
3/8	–	15F	1/2-14	2.55	1.00	1.16	0.46
1/2	–	17E	3/8-18	2.74	1.00	1.19	0.46
1/2	B17	17	1/2-14	2.96	1.00	1.19	0.50
1/2	–	17G	3/4-14	3.19	1.25	1.44	0.20

##### Male Pipe Thread

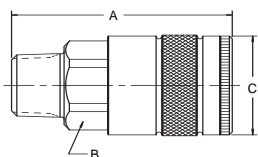

Body Size (in.)	Part No. Brass	Part No. Steel	Thread Size NPTF	Dimensions (in.)			Wt. (LB) P/Piece
				Overall Length	Hex Size	Largest Diameter	
				A	B	C	
1/4	B12A	–	1/8-27	1.89	0.75	0.90	0.17
1/4	B12	–	1/4-18	2.05	0.75	0.90	0.18
1/4	B12E	–	3/8-18	2.08	0.75	0.90	0.19
3/8	–	14C	1/4-18	2.36	0.88	1.06	0.26
3/8	B14	14	3/8-18	2.39	0.88	1.06	0.27
3/8	–	14F	1/2-14	2.55	0.88	1.06	0.28
1/2	–	16E	3/8-18	2.93	1.00	1.19	0.42
1/2	B16	16	1/2-14	3.08	1.00	1.19	0.45
1/2	–	16G	3/4-14	3.21	1.13	1.30	0.50

##### Standard Hose Barb

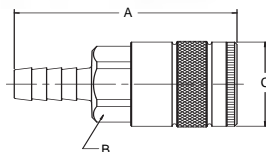

Body Size (in.)	Part No. Brass	Part No. Steel	Hose I.D.	Dimensions (in.)			Wt. (LB) P/Piece
				Overall Length	Hex Size	Largest Diameter	
				A	B	C	
1/4	B10-3B	–	1/4	2.49	0.75	0.90	0.18
1/4	B10-4B	–	5/16	2.49	0.75	0.90	–
1/4	B10-5B	–	3/8	2.49	0.75	0.90	0.18
3/8	–	14-5B	3/8	2.86	0.88	1.06	0.26
3/8	–	14-6B	1/2	3.08	0.88	1.06	0.27
1/2	–	16-5B	3/8	3.37	1.00	1.19	0.41
1/2	–	16-6B	1/2	3.62	1.00	1.19	0.43
1/2	–	16-7B	3/4	3.96	1.00	1.19	0.48

##### Push-Lok Hose Barb\*

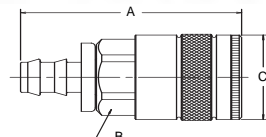

Body Size (in.)	Part No. Brass	Part No. Steel	Hose I.D.	Dimensions (in.)			Wt. (LB) P/Piece
				Overall Length	Hex Size	Largest Diameter	
				A	B	C	
1/4	B10-3BP	–	1/4	2.32	0.75	0.90	0.19
1/4	B10-5BP	–	3/8	2.47	0.75	0.90	0.19
3/8	–	14-5BP	3/8	2.88	0.88	1.06	0.26
1/2	–	16-5BP	3/8	3.35	1.00	1.19	0.40
1/2	–	16-6BP	1/2	3.46	1.00	1.19	0.43

\* Push-Lok hose barbs are designed for use with Parker Push-Lok hose and do not require clamps.

## Pneumatic Quick Couplings

## General Purpose – Manual Connect 10 Series

### Nipples

#### Female Pipe Thread

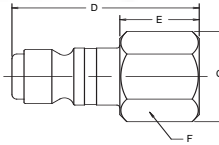

Body Size (in.)	Part No. Brass	Part No. Steel	Thread Size NPTF	Dimensions (in.)				Wt. (LB) P/Piece
				Overall Length	Exposed Length*	Hex Size	Largest Diameter	
				D	E	F	G	
1/4	–	1C	1/8-27	1.28	0.55	0.50	0.58	0.05
1/4	B3C	3C	1/4-18	1.47	0.74	0.62	0.72	0.05
1/4	–	3C-E	3/8-18	1.50	0.77	0.81	0.94	0.07
3/8	–	1E	1/4-18	1.60	0.67	0.62	0.72	0.07
3/8	–	3E	3/8-18	1.68	0.77	0.81	0.94	0.10
1/2	–	1F	3/8-18	2.05	0.83	0.81	0.94	0.13
1/2	–	3F	1/2-14	2.27	1.05	1.00	1.16	0.18
1/2	–	H3F-G	3/4-14	2.38	1.13	1.25	1.44	0.26

\* This dimension represents portion of nipple that is exposed when nipple is inserted in a Parker 10 Series coupler.

#### Male Pipe Thread

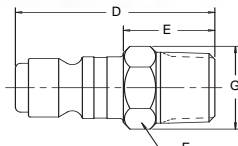

Body Size (in.)	Part No. Brass	Part No. Steel	Part No. Type 303 Stainless	Thread Size NPTF	Dimensions (in.)				Wt. (LB) P/Piece
					Overall Length	Exposed Length*	Hex Size	Largest Diameter	
					D	E	F	G	
1/4	–	0C	–	1/8-27	1.47	0.74	0.50	0.58	0.04
1/4	B2C	2C	S2C	1/4-18	1.62	0.89	0.56	0.65	0.06
1/4	–	2C-E	–	3/8-18	1.72	0.99	0.69	0.80	0.05
3/8	–	0E	–	1/4-18	1.88	0.95	0.62	0.72	0.08
3/8	–	2E	–	3/8-18	1.90	0.98	0.69	0.80	0.09
1/2	–	0F	–	3/8-18	2.33	1.12	0.69	0.79	0.13
1/2	–	2F	–	1/2-14	2.48	1.27	0.88	1.01	0.17
1/2	–	H2F-G	–	3/4-14	2.53	1.29	1.13	1.30	0.24

\* This dimension represents portion of nipple that is exposed when nipple is inserted in a Parker 10 Series coupler.

#### Standard Hose Barb

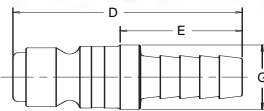

Body Size (in.)	Part No. Steel	Hose I.D.	Overall Length	Dimensions (in.)		Wt. (LB) P/Piece
				Exposed Length*	Largest Diameter	
			D	E	G	
1/4	8C	1/4	1.63	.090	0.45	0.04
1/4	9C	3/8	2.00	1.27	0.55	0.05
3/8	5E	3/8	1.81	0.89	0.59	0.07
1/2	H4F	3/8	2.53	1.29	0.69	0.08
1/2	5F	1/2	2.81	1.60	0.81	0.11
1/2	H5F-G	3/4	3.16	1.91	0.94	0.18

\* This dimension represents portion of nipple that is exposed when nipple is inserted in a Parker 10 Series coupler.

#### Push-Lok Hose Barb\*\*

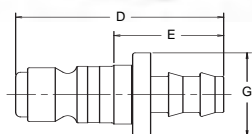

Body Size (in.)	Part No. Steel	Hose I.D.	Overall Length	Dimensions (in.)		Wt. (LB) P/Piece
				Exposed Length*	Largest Diameter	
			D	E	G	
1/4	8CP	1/4	1.66	0.93	0.45	0.04
1/4	9CP	3/8	1.98	1.25	0.86	0.05
3/8	5EP	3/8	1.98	1.06	0.59	0.08
1/2	H4FP	3/8	2.52	1.27	0.86	0.11
1/2	H5FP	1/2	2.66	1.42	0.97	0.11

\* This dimension represents portion of nipple that is exposed when nipple is inserted in a Parker 10 Series coupler.

\*\* Push-Lok hose barbs are designed for use with Parker Push-Lok hose and do not require clamps.

## Pneumatic Quick Couplings

## General Purpose – Manual Connect 20 Series Industrial Interchange



### Features

- Parker 20 Series sleeve type couplers accept industrial interchange nipples manufactured by Parker and other manufacturers.
- Standard seals are Nitrile. See the Coupling Selection and Ordering Information Guide at the beginning of Section A and the Fluid Compatibility Chart at the end of this catalog for optional materials.

### Specifications

Body Size (in.)	1/4	3/8	1/2
Rated Pressure (psi)	300	300	300
Temperature Range (Std. seals)*	-40° to +250° F.		
Locking Device	4 balls	8 balls	8 balls
Vacuum Data (inches Hg)	<b>Not recommended</b>		
Disconnected (coupler only)	<b>Not recommended</b>		
Connected	27.4	27.4	27.4

\* See Coupling Selection and Ordering Guide for Optional Seals  
See **Coupling Repair Kits** Table on introduction page to General Purpose - Manual Connect Couplers

### How to Order Information

The standard 1/4" 20 Series is a brass coupler with a steel valve. The larger sizes are an all steel construction with brass available as an option. To order a 3/8" or 1/2" body size coupler with a brass body and a steel sleeve and valve, add the prefix "B" to the steel part number. Example: B16.

Add the suffix "N" as well as the "B" prefix to order an all brass coupler with stainless steel locking balls and springs, Example: B25N. All-brass couplings should be used to avoid corrosion from moisture. Consult factory for specific recommendations.

Available with Sleeve-Lok (See Coupler Options at the beginning of Section A). To order, add "-SL" as a suffix to the part number, Example: 25-SL.

Available for 1/4" 20 Series couplers is a Grip-Ring sleeve (See Coupler Options). To order, add the suffix "R" to the part number, Example: B23R.

### Applications

Sleeve type couplings are widely used to connect air lines and can also be used with low pressure fluids.

Their compact and economical design uses a ball locking mechanism consisting of captive steel balls that engage the locking groove on the mating nipple. The sliding spring loaded sleeve on the coupler must be manually retracted in order to connect or disconnect the nipple. It is easy to do, but two hands are normally required.

Common applications include: compressed air, water, grease, paint, limited vacuum and limited gases.

### Performance

20 Series (1/4", 3/8", 1/2" sizes)

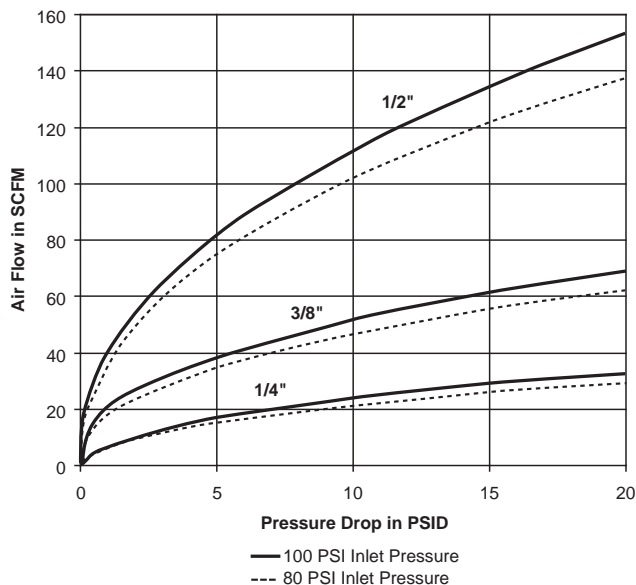

Couplers

Female Pipe Thread

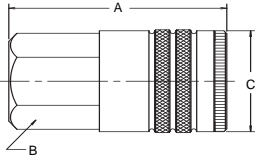

Body Size (in.)	Part No. Brass	Part No. Steel	Part No. Type 303 Stainless	Thread Size NPTF	Dimension (in.)			Wt. (LB) P/Piece
					Overall Length	Hex Size	Largest Diameter	
					A	B	C	
1/4	B23A	–	–	1/8-27	1.83	0.75	0.90	0.20
1/4	B23	–	S23	1/4-18	1.83	0.75	0.90	0.19
1/4	B23E	–	–	3/8-18	1.95	0.81	0.94	0.20
3/8	–	25C	–	1/4-18	2.22	0.88	1.06	0.30
3/8	B25	25	–	3/8-18	2.28	0.88	1.06	0.32
3/8	–	25F	–	1/2-14	2.55	1.00	1.16	0.34
1/2	–	17E	–	3/8-18	2.74	1.00	1.19	0.46
1/2	B17	17	–	1/2-14	2.96	1.00	1.19	0.50
1/2	–	17G	–	3/4-14	3.19	1.25	1.44	0.56

Male Pipe Thread

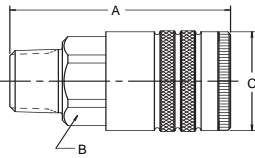

Body Size (in.)	Part No. Brass	Part No. Steel	Part No. Type 303 Stainless	Thread Size NPTF	Dimension (in.)			Wt. (LB) P/Piece
					Overall Length	Hex Size	Largest Diameter	
					A	B	C	
1/4	B22A	–	–	1/8-27	1.89	0.75	0.90	0.18
1/4	B22	–	S22	1/4-18	2.05	0.75	0.90	0.18
1/4	B22E	–	–	3/8-18	2.08	0.75	0.90	0.19
3/8	–	24C	–	1/4-18	2.36	0.88	1.06	0.26
3/8	B24	24	–	3/8-18	2.39	0.88	1.06	0.29
3/8	–	24F	–	1/2-14	2.55	0.88	1.06	0.29
1/2	–	16E	–	3/8-18	2.93	1.00	1.19	0.42
1/2	B16	16	–	1/2-14	3.08	1.00	1.19	0.47
1/2	–	16G	–	3/4-14	3.21	1.13	1.30	0.50

Standard Hose Barb

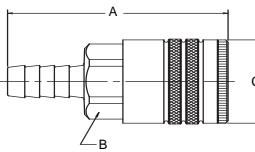

Body Size (in.)	Part No. Brass	Part No. Steel	Hose I.D.	Dimensions (in.)			Wt. (LB) P/Piece
				Overall Length	Hex Size	Largest Diameter	
				A	B	C	
1/4	B20-3B	–	1/4	2.49	0.75	0.90	0.18
1/4	B20-4B	–	5/16	2.49	0.75	0.90	0.18
1/4	B20-5B	–	3/8	2.49	0.75	0.90	0.18
3/8	–	24-5B	3/8	2.86	0.88	1.06	0.27
3/8	–	24-6B	1/2	3.08	0.88	1.06	0.28
1/2	–	16-5B	3/8	3.37	1.00	1.19	0.41
1/2	–	16-6B	1/2	3.62	1.00	1.19	0.43
1/2	–	16-7B	3/4	3.96	1.00	1.19	0.48

Push-Lok Hose Barb\*

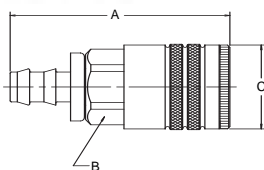

Body Size (in.)	Part No. Brass	Part No. Steel	Hose I.D.	Dimensions (in.)			Wt. (LB) P/Piece
				Overall Length	Hex Size	Largest Diameter	
				A	B	C	
1/4	B20-3BP	–	1/4	2.32	0.75	0.90	0.18
1/4	B20-5BP	–	3/8	2.47	0.75	0.90	0.19
3/8	–	24-5BP	3/8	2.88	0.88	1.06	0.27
1/2	–	16-5BP	3/8	3.35	1.00	1.19	0.40
1/2	–	16-6BP	1/2	3.46	1.00	1.19	0.43

\* Push-Lok hose barbs are designed for use with Parker Push-Lok hose and do not require clamps.

**Note:** See Table of Contents for those nipples used with 20 Series couplers.



## Pneumatic Quick Couplings

## General Purpose – Manual Connect

50 Series



### Features

- Parker 50 Series couplings are interchangeable with ARO's 210 series couplings.
- 50 Series couplings have a full opening tubular valve for maximum flow and a built-in sleeve guard to minimize accidental disconnect.
- 50 Series couplings have all brass bodies and steel valves.
- Standard seal material is Nitrile. See the Coupling Selection and Ordering Information guide at the beginning of Section A and the Fluid Compatibility Chart at the end of this catalog for optional materials.
- Push-to-Connect version available. See HA Series.

### Specifications

Body Size (in.)	1/4
Rated Pressure (PSI)	300
Temperature Range (Std. seals)*	-40° to +250° F.
Locking Device	4 balls

\* See Coupling Selection and Ordering Guide for Optional Seals.

See **Coupling Repair Kits** Table on introduction page to General Purpose - Manual Connect Couplers

### Performance

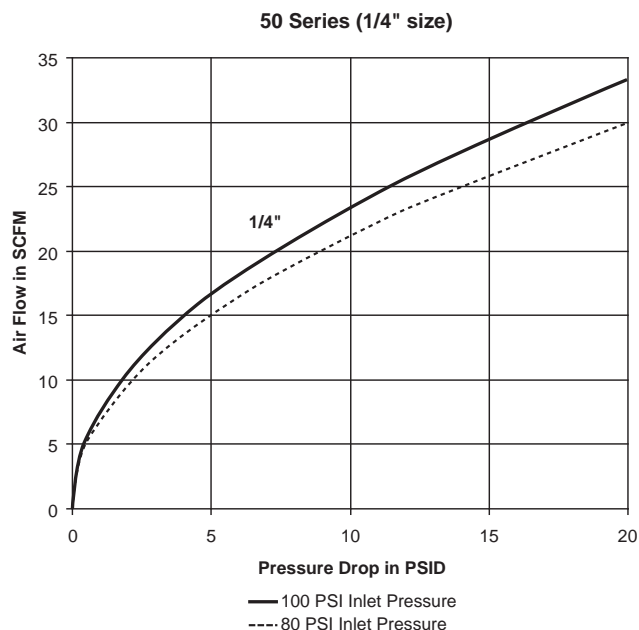

### Couplers

#### Female Pipe Thread

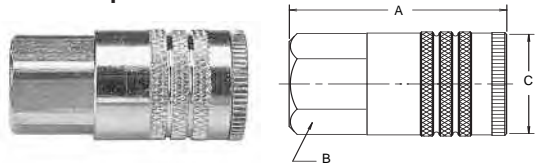

Body Size (in.)	Part No. Brass	Thread Size NPTF	Dimensions (in.)			Wt. (LB) P/Piece
			Overall Length	Hex Size	Largest Diameter	
			A	B	C	
1/4	B53	1/4-18	1.83	0.75	0.90	0.20
1/4	B53E	3/8-18	1.95	0.81	0.94	0.21

#### Male Pipe Thread

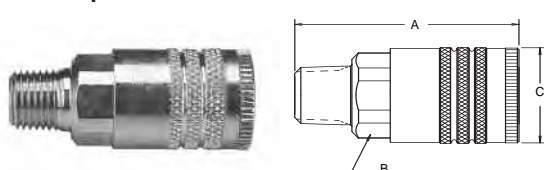

Body Size (in.)	Part No. Brass	Thread Size NPTF	Dimensions (in.)			Wt. (LB) P/Piece
			Overall Length	Hex Size	Largest Diameter	
			A	B	C	
1/4	B52	1/4-18	2.05	0.75	0.90	0.20
1/4	B52E	3/8-18	2.08	0.75	0.90	0.21

#### Push-Lok Hose Barb\*

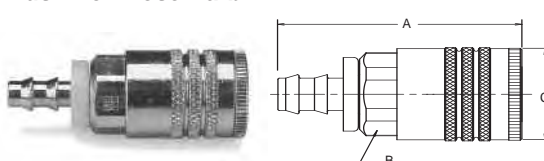

Body Size (in.)	Part No. Brass	Hose I.D.	Dimensions (in.)			Wt. (LB) P/Piece
			Overall Length	Hex Size	Largest Diameter	
			A	B	C	
1/4	B50-3BP	1/4	2.32	0.75	0.90	0.19
1/4	B50-5BP	3/8	2.47	0.75	0.90	0.20

\* Push-Lok hose barbs are designed for use with Push-Lok hose and do not require clamps.



## Pneumatic Quick Couplings

### General Purpose – Manual Connect 50 Series

#### Nipples

##### Female Pipe Thread

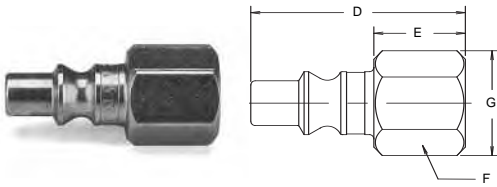

Body Size (in.)	Part No. Steel	Thread Size NPTF	Overall Length	Dimensions (in.)			Wt. (LB) P/Piece
				Exposed Length*	Hex Size	Largest Diameter	
			D	E	F	G	
1/4	A3C	1/4-18	1.47	0.66	0.62	0.72	0.04

\* This dimension represents portion of nipple that is exposed when nipple is inserted in a Parker 50 Series coupler.

##### Male Pipe Thread

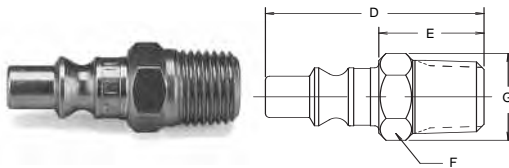

Body Size (in.)	Part No. Steel	Thread Size NPTF	Overall Length	Dimensions (in.)			Wt. (LB) P/Piece
				Exposed Length*	Hex Size	Largest Diameter	
			D	E	F	G	
1/4	A2C	1/4-18	1.62	0.82	0.56	0.65	0.05

\* This dimension represents portion of nipple that is exposed when nipple is inserted in a Parker 50 Series coupler.

##### Standard Hose Barb

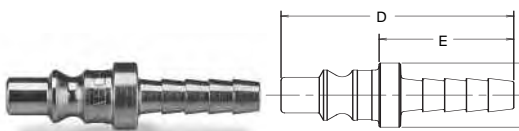

Body Size (in.)	Part No. Steel	Hose I.D.	Overall Length	Dimensions (in.)		Wt. (LB) P/Piece
				Exposed Length*	Largest Diameter	
			D	E	G	
1/4	A8C	1/4	1.63	0.85	.043	0.03

\* This dimension represents portion of nipple that is exposed when nipple is inserted in a Parker 50 Series coupler.

##### Push-Lok Hose Barb\*\*

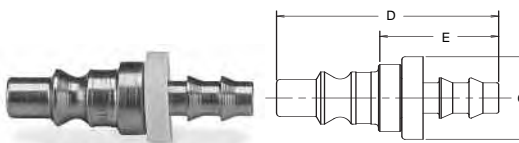

Body Size (in.)	Part No. Steel	Hose I.D.	Overall Length	Dimensions (in.)		Wt. (LB) P/Piece
				Exposed Length*	Largest Diameter	
			D	E	G	
1/4	A8CP	1/4	1.65	0.87	0.67	0.03

\* This dimension represents portion of nipple that is exposed when nipple is inserted in a Parker 50 Series coupler.

\*\* Push-Lok hose barbs are designed for use with Parker push-lok hose and do not require clamps.

# Pneumatic Quick Couplings

## General Purpose – Manual Connect

### 70 Series



### Features

- Parker 70 Series couplings are interchangeable with Lincoln's "Long Stem" series couplings.
- 70 Series couplings have a full opening tubular valve for maximum flow and a built-in sleeve guard to minimize accidental disconnect.
- The 70 Series is only available in 1/4" body size.
- 70 Series couplings have all brass bodies and steel valves.
- Standard seal material is Nitrile. See the Coupling Selection and Ordering Information Guide at the beginning of Section A and the Fluid Compatibility Chart at the end of this catalog for optional materials.

### Couplers

#### Female Pipe Thread

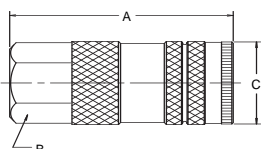

Body Size (in.)	Part No. Brass	Thread Size NPTF	Dimensions (in.)			Wt. (LB) P/Piece
			Overall Length	Hex Size	Largest Diameter	
			A	B	C	
1/4	B73	1/4-18	2.40	0.75	0.90	0.25

#### Male Pipe Thread

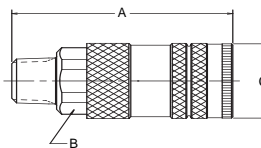

Body Size (in.)	Part No. Brass	Thread Size NPTF	Dimensions (in.)			Wt. (LB) P/Piece
			Overall Length	Hex Size	Largest Diameter	
			A	B	C	
1/4	B72	1/4-18	2.62	0.75	0.90	0.25

### Nipples

#### Female Pipe Thread

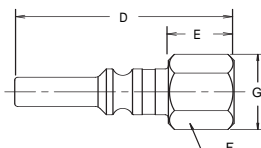

Body Size (in.)	Part No. Steel	Thread Size NPTF	Dimensions (in.)			
			Overall Length	Exposed Length*	Hex Size	Largest Diameter
			D	E	F	G
1/4	L3C	1/4-18	2.10	0.77	0.62	0.72

#### Male Pipe Thread

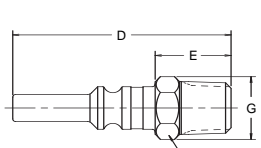

Body Size (in.)	Part No. Steel	Thread Size NPTF	Dimensions (in.)			
			Overall Length	Exposed Length*	Hex Size	Largest Diameter
			D	E	F	G
1/4	L2C	1/4-18	2.25	0.92	0.56	0.65

\* This dimension represents portion of nipple that is exposed when nipple is inserted in a Parker 70 Series coupler.

### Specifications

Body Size (in.)	1/4
Rated Pressure (psi)	300
Temperature Range (Std. seals)*	-40° to +250° F.
Locking Device	4 balls

\* See Coupling Selection and Ordering Guide for Optional Seals.

See **Coupling Repair Kits** Table on introduction page to General Purpose - Manual Connect Couplers

### Performance

70 Series (1/4" size)

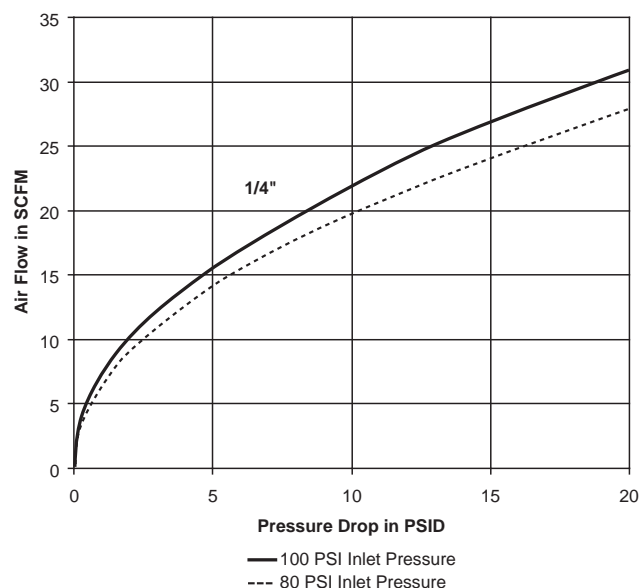

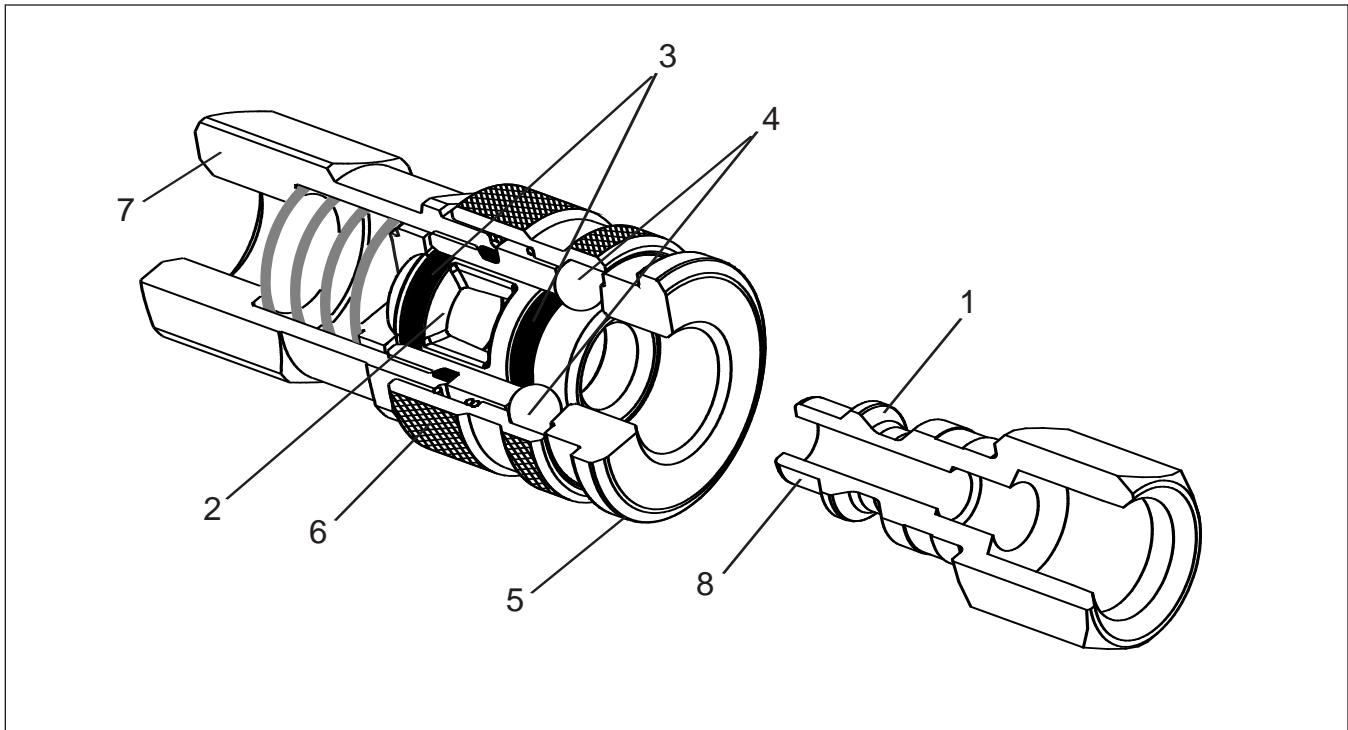

**Component Part Features**

1. Precision machining, hardened wear points\* and solid bar stock construction provide long life even in rugged applications.
  2. Tubular valve with large flow passages delivers high flow with minimum pressure drop for efficient performance. The tubular design provides 360° support for both the valve seal and the mating nipple for long service life.
  3. Precision molded seals form a “bubble tight” seal for reliable operation within rated working pressures. Standard seal material is Nitrile. Ethylene Propylene, Fluorocarbon and Neoprene are available as options. See the Coupling Selection and Ordering Guide in the front of the Pneumatic Section of the catalog.
  4. Proven ball locking mechanism with large numbers of hardened steel or stainless steel locking balls evenly distribute the load to resist wear and provide positive connections. The ball locking mechanism also provides accurate alignment and allows a swiveling action to reduce hose torque.
  5. Integral sleeve guard protects the sleeve and resists accidental disconnects by allowing the coupling to ride over obstructions without the sleeve being retracted.
  6. Knurling on the sleeve provides a gripping surface for ease of operation.
  7. Wide range of end configurations are available to meet specific needs. Parker push-to-connect type couplings are available with male pipe thread, female pipe thread, standard hose barb, and Push-Lok hose barb\*\*.
  8. Parker 20, 30, HF, and E-z-mate Series couplings mate with industrial interchange design nipples. See Table of Contents for additional specifications.
  9. Push-to-connect design permits one-handed connection when the coupler half is rigidly mounted.
- \* steel nipples only
- \*\* Push-Lok hose barbs are designed for use with Parker Push-Lok hose and do not require clamps.

## Pneumatic Quick Couplings

## General Purpose – Push-To-Connect RF Series



### Features

- Aerodynamic valve design.
- Flow area of the RF nipple is up to 2-1/2 times larger than industrial interchange nipples.
- Flow rates on 1/4" greater than many 3/8" body size couplers.
- Flow rates on 3/8" greater than many 1/2" body size couplers.
- Coupler sleeves are nickel-plated steel and coupler bodies are solid brass construction for excellent corrosion resistance. Standard RF nipples are manufactured from solid steel bar stock, case hardened and Chromium-6 Free plated.
- Dependable ball locking mechanism allows a swiveling action to reduce hose torque.
- Push-To-Connect design for easy one hand connection.
- Integral sleeve guard to protect against accidental disconnection.
- Wide range of port options available.
- More efficient use of compressed air due to higher flows and reduced pressure drop.
- 1/4" body size interchanges with Rectus 25 and Cejn 320 series.
- 3/8" body size interchanges with Rectus 27 and Cejn 410 series.

### Specifications

Body Size (in.)	1/4	3/8
Rated Pressure (psi)	300	300
Temperature Range (std seals)	-40° to +250°F	-40° to +250°F
Locking Device	4 balls	8 balls
Vacuum Data (inches Hg)		
Disconnected (coupler only)	Not Recommended	Not Recommended
Connected	Not Recommended	Not Recommended

### Description

The Parker RF Series pneumatic couplings offer the quality and dependability customers have come to expect from Parker's line of pneumatic quick couplings. The RF Series has been designed to increase the flow through and reduce the pressure drop over the coupling. The nipple design has up to 2-1/2 times larger flow area than standard industrial interchange nipples. This, along with a specially designed coupler valve, allows tremendous flow through a coupling with an envelope size of current couplings in the market today. The benefits to the end user are increased tool efficiency and decreased air costs.

### Performance

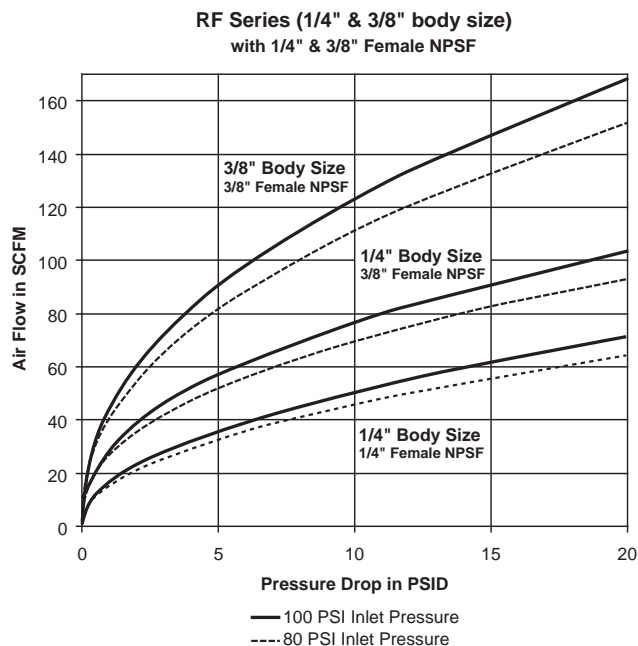

### How To Order

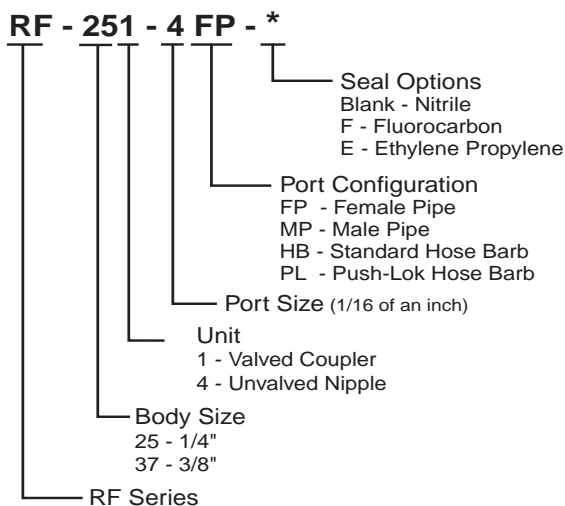

Couplers

Female Pipe Thread

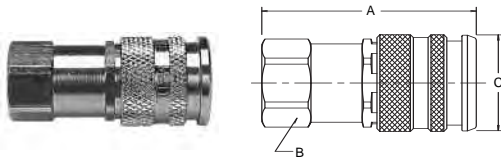

Body Size (in.)	NEW Part No.	OLD Part No.	Thread Size NPSF	Dimensions (in.)			Wt. (LB) P/Piece
				Overall Length	Hex Size	Largest Diameter	
				A	B	C	
1/4	RF-251-4FP	CRF02-4-4	1/4-18	2.19	0.81	0.99	0.26
1/4	RF-251-6FP	CRF02-4-6	3/8-18	2.34	0.81	0.99	0.27
3/8	RF-371-6FP	–	3/8-18	2.33	0.94	1.07	0.31
3/8	RF-371-8FP	–	1/2-14	2.49	1.00	1.07	0.35

Male Pipe Thread

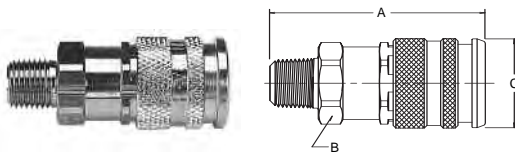

Body Size (in.)	NEW Part No.	OLD Part No.	Thread Size NPTF	Dimensions (in.)			Wt. (LB) P/Piece
				Overall Length	Hex Size	Largest Diameter	
				A	B	C	
1/4	RF-251-4MP	CRF01-4-4	1/4-18	2.34	0.81	0.99	0.24
1/4	RF-251-6MP	CRF01-4-6	3/8-18	2.37	0.81	0.99	0.25
1/4	RF-251-8MP	CRF01-4-8	1/2-14	2.56	0.88	0.99	0.29
3/8	RF-371-6MP	–	3/8-18	2.52	0.94	1.07	0.30
3/8	RF-371-8MP	–	1/2-14	2.68	0.94	1.07	0.33

Standard Hose Barb

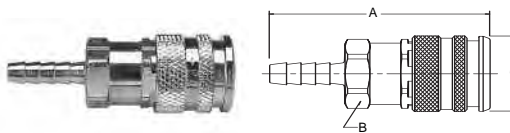

Body Size (in.)	NEW Part No.	OLD Part No.	Hose I.D.	Dimensions (in.)			Wt. (LB) P/Piece
				Overall Length	Hex Size	Largest Diameter	
				A	B	C	
1/4	RF-251-4HB	CRFHB-4-4	1/4	2.81	0.81	0.99	0.26
1/4	RF-251-6HB	CRFHB-4-6	3/8	2.81	0.81	0.99	0.27
3/8	RF-371-6HB	–	3/8	3.02	0.94	1.07	0.31
3/8	RF-371-8HB	–	1/2	3.02	0.94	1.07	0.34

Push-Lok Hose Barb

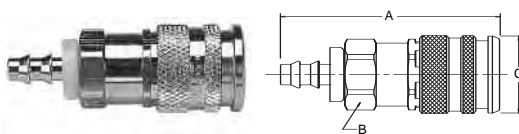

Body Size (in.)	NEW Part No.	OLD Part No.	Hose I.D.	Dimensions (in.)			Wt. (LB) P/Piece
				Overall Length	Hex Size	Largest Diameter	
				A	B	C	
1/4	RF-251-4PL	CRFPL-4-4	1/4	2.64	0.81	0.99	0.26
1/4	RF-251-6PL	CRFPL-4-6	3/8	2.78	0.81	0.99	0.27
1/4	RF-251-8PL	CRFPL-4-8	1/2	2.93	0.81	0.99	0.28
3/8	RF-371-6PL	–	3/8	3.02	0.94	1.07	0.33
3/8	RF-371-8PL	–	1/2	3.02	0.94	1.07	0.33



## Pneumatic Quick Couplings

## General Purpose – Push-To-Connect RF Series

### Nipples

#### Female Pipe Thread

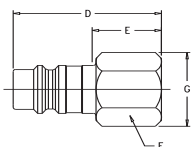

Body Size (in.)	NEW Part No.	OLD Part No.	Thread Size NPTF	Dimensions (in.)				Wt. (LB) P/Piece
				Overall Length	Exposed* Length	Hex Size	Largest Diameter	
				D	E	F	G	
1/4	RF-254-4FP	NRF02-4-4-S	1/4-18	1.45	0.68	0.62	0.72	0.06
1/4	RF-254-6FP	NRF02-4-6-S	3/8-18	1.50	0.73	0.81	0.94	0.09
3/8	RF-374-6FP	–	3/8-18	1.53	0.78	0.81	0.94	0.10
3/8	RF-374-8FP	–	1/2-14	1.62	0.87	1.00	1.16	0.13

#### Male Pipe Thread

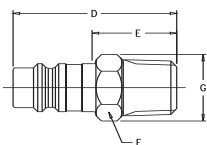

Body Size (in.)	NEW Part No.	OLD Part No.	Thread Size NPTF	Dimensions (in.)				Wt. (LB) P/Piece
				Overall Length	Exposed* Length	Hex Size	Largest Diameter	
				D	E	F	G	
1/4	RF-254-4MP	NRF01-4-4-S	1/4-18	1.60	0.83	0.56	0.65	0.05
1/4	RF-254-6MP	NRF01-4-6-S	3/8-18	1.67	0.90	0.69	0.75	0.08
3/8	RF-374-6MP	–	3/8-18	1.70	0.95	0.69	0.75	0.09
3/8	RF-374-8MP	–	1/2-14	1.85	1.10	0.88	1.01	0.15

#### Standard Hose Barb

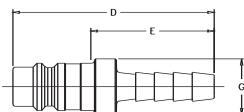

Body Size (in.)	NEW Part No.	OLD Part No.	Hose I.D.	Dimensions (in.)			Wt. (LB) P/Piece
				Overall Length	Exposed* Length	Largest Diameter	
				D	E	G	
1/4	RF-254-4HB	NRFHB-4-4-S	1/4	1.66	0.89	0.50	0.04
1/4	RF-254-6HB	NRFHB-4-6-S	3/8	1.66	0.89	0.50	0.05
3/8	RF-374-6HB	–	3/8	1.63	0.88	0.59	0.07
3/8	RF-374-8HB	–	1/2	1.97	1.22	0.68	0.08

#### Push-Lok Hose Barb

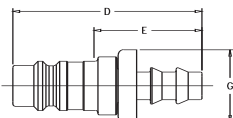

Body Size (in.)	NEW Part No.	OLD Part No.	Hose I.D.	Dimensions (in.)			Wt. (LB) P/Piece
				Overall Length	Exposed* Length	Largest Diameter	
				D	E	G	
1/4	RF-254-4PL	NRFPL-4-4-S	1/4	1.69	0.92	0.50	0.04
1/4	RF-254-6PL	NRFPL-4-6-S	3/8	1.83	1.06	0.50	0.05
3/8	RF-374-6PL	–	3/8	1.80	1.05	0.59	0.07
3/8	RF-374-8PL	–	1/2	2.09	1.34	0.897	0.09

\* This dimension represents portion of nipple that is exposed when nipple is inserted in a Parker RF Series coupler.



### Features

- Parker HF Series Pneumatic Quick Couplings offer an alternative to traditional industrial interchange couplers. The quality and durability you have come to expect from Parker 20 Series couplers, combined with a slim profile and push-to-connect design. The result is an easy to use general purpose pneumatic coupler suitable for use in a variety of applications.
- Parker HF couplers feature sleeve guards\*\* to protect against accidental disconnection.
- Standard couplers feature solid brass construction, high flow valving, corrosion resistant valves, and stainless steel locking balls and valve spring.
- Heavy Duty Couplers\* featuring heat treated, solid steel bodies and sleeves for added strength and durability.
- Parker HF couplers accept Industrial Interchange nipples\*\*\* manufactured by Parker and other manufacturers. See table of contents.

\*\*\* 1/8" couplings have no standard industry interface.

\*\* 1/8" couplings do not incorporate an integral sleeve guard.

\* 1/8" and 1/2" are unavailable in the Heavy Duty version.

### How To Order

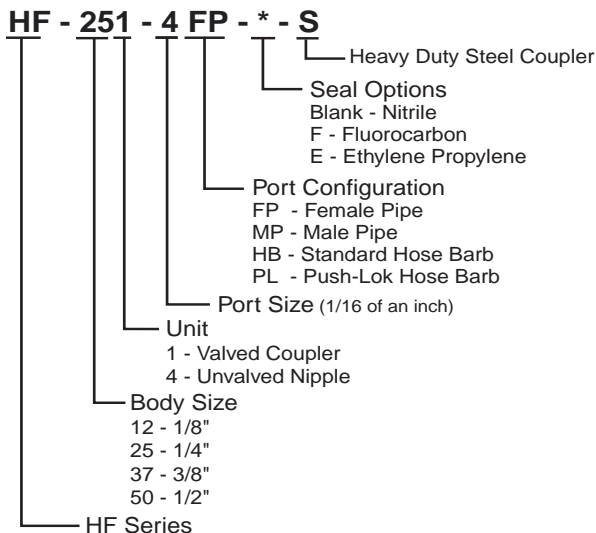

### Specifications

Body Size (in.)	1/8	1/4	3/8	1/2
Rated Pressure (psi)	250	300	300	300
Temperature Range (Std. seals)	-40° to +250°F			
Locking Device	5 balls	4 balls	6 balls	8 balls
Vacuum Data (inches Hg)				
Disconnected (coupler only)	<b>Not Recommended</b>			
Connected	—	27.4	27.4	27.4

### Performance

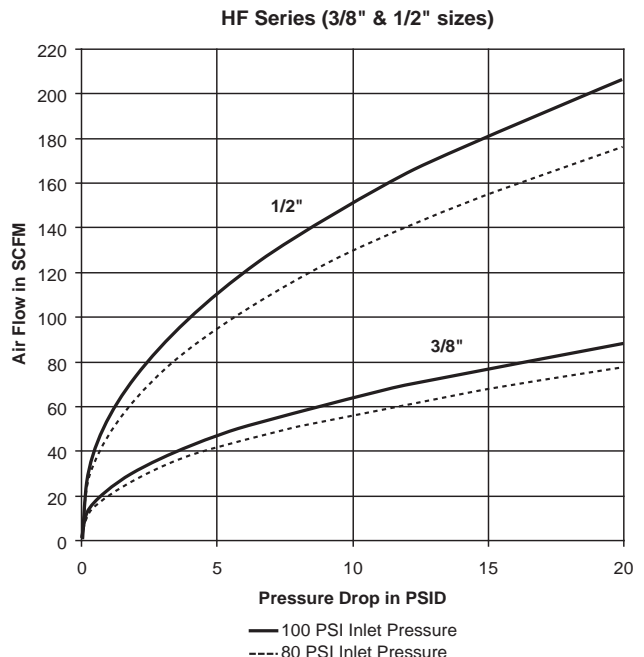
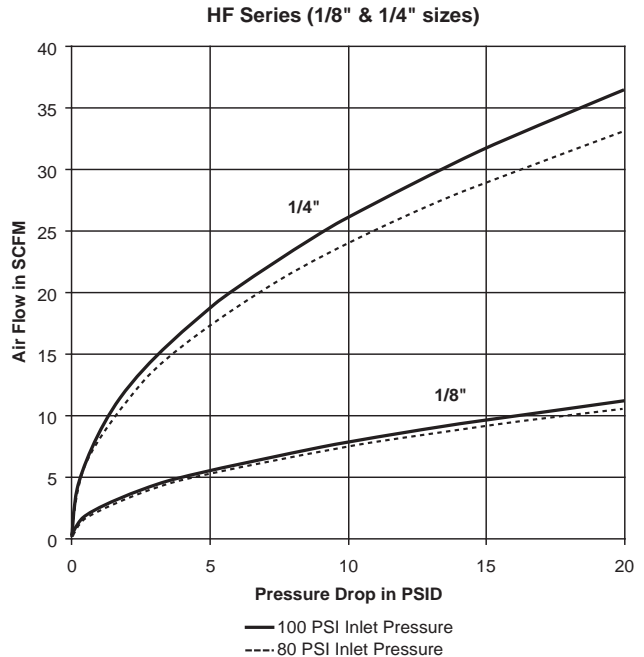

## Pneumatic Quick Couplings

## General Purpose – Push-To-Connect HF Series Industrial Interchange

### 1/8" Body Size Couplers

#### Female Pipe Thread

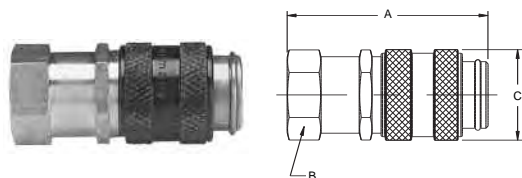

Body Size (in.)	New Part No. Brass	Old Part No. Brass	Thread Size NPTF	Dimensions (in.)			Wt. (LB) P/Piece
				Overall Length	Hex Size	Largest Diameter	
				A	B	C	
1/8	HF-121-2FP	HF302F-2	1/8-27	1.42	0.55	0.63	0.06
1/8	HF-121-4FP	HF302F-4	1/4-18	1.81	0.67	0.63	0.10

#### Male Pipe Thread

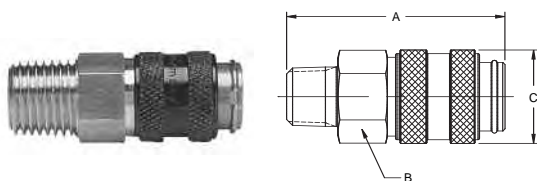

Body Size (in.)	New Part No. Brass	Old Part No. Brass	Thread Size NPTF	Dimensions (in.)			Wt. (LB) P/Piece
				Overall Length	Hex Size	Largest Diameter	
				A	B	C	
1/8	HF-121-2MP	HF302M-2	1/8-27	1.50	0.55	0.63	0.06
1/8	HF-121-4MP	HF302M-4	1/4-18	1.61	0.55	0.63	0.07

### 1/8" Body Size Nipples

#### Female Pipe Thread

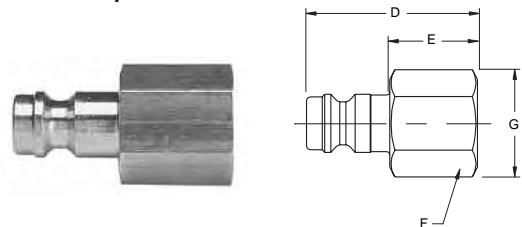

Body Size (in.)	New Part No. Brass	Old Part No. Brass	Thread Size NPTF	Dimensions (in.)				Wt. (LB) P/Piece
				Overall Length	Exposed Length*	Hex Size	Largest Diameter	
				D	E	F	G	
1/8	HF-124-2FP	HF702F-2	1/8-27	1.08	0.55	0.50	0.58	0.03
1/8	HF-124-4FP	HF702F-4	1/4-18	1.34	0.81	0.67	0.78	0.07

\* This dimension represents the portion that is exposed when nipple is inserted in a Parker HF series coupler.

#### Male Pipe Thread

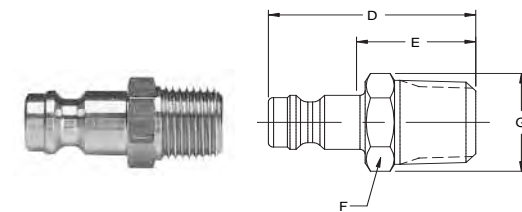

Body Size (in.)	New Part No. Brass	Old Part No. Brass	Thread Size NPTF	Dimensions (in.)				Wt. (LB) P/Piece
				Overall Length	Exposed Length*	Hex Size	Largest Diameter	
				D	E	F	G	
1/8	HF-124-2MP	HF702M-2	1/8-27	1.06	0.53	0.44	0.51	0.03
1/8	HF-124-4MP	HF702M-4	1/4-18	1.25	0.72	0.56	0.63	0.05

\* This dimension represents the portion that is exposed when nipple is inserted in a Parker HF series coupler.

## Pneumatic Quick Couplings

## General Purpose – Push-To-Connect HF Series Industrial Interchange

### 1/4", 3/8", & 1/2" Body Size Couplers

#### Female Pipe Thread

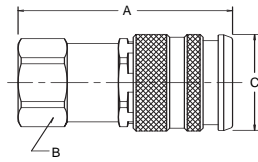

Body Size (in.)	New Part No. Brass	Old Part No. Brass	Thread Size NPSF	Dimensions (in.)			Wt. (LB) P/Piece
				Overall Length	Hex Size	Largest Diameter	
				A	B	C	
1/4	HF-251-4FP	HF304F-4	1/4-18	2.19	0.81	0.99	0.26
1/4	HF-251-6FP	HF304F-6	3/8-18	2.34	0.81	0.99	0.27
3/8	HF-371-4FP	HF306F-4	1/4-18	2.33	0.94	1.07	0.33
3/8	HF-371-6FP	HF306F-6	3/8-18	2.33	0.94	1.07	0.31
3/8	HF-371-8FP	HF306F-8	1/2-14	2.49	1.00	1.07	0.35
1/2	HF-501-8FP	–	1/2-14	3.35	1.06	1.19	0.60

#### Male Pipe Thread

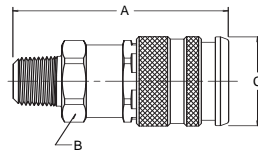

Body Size (in.)	New Part No. Brass	Old Part No. Brass	Thread Size NPTF	Dimensions (in.)			Wt. (LB) P/Piece
				Overall Length	Hex Size	Largest Diameter	
				A	B	C	
1/4	HF-251-4MP	HF304M-4	1/4-18	2.34	0.81	0.99	0.25
1/4	HF-251-6MP	HF304M-6	3/8-18	2.37	0.81	0.99	0.26
3/8	HF-371-4MP	HF306M-4	1/4-18	2.49	0.94	1.07	0.32
3/8	HF-371-6MP	HF306M-6	3/8-18	2.52	0.94	1.07	0.30
3/8	HF-371-8MP	HF306M-8	1/2-14	2.68	0.94	1.07	0.33
1/2	HF-501-8MP	–	1/2-14	3.48	1.06	1.19	0.57

#### Standard Hose Barb

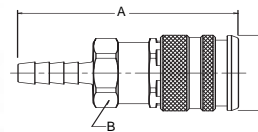

Body Size (in.)	New Part No. Brass	Old Part No. Brass	Hose I.D.	Dimensions (in.)			Wt. (LB) P/Piece
				Overall Length	Hex Size	Largest Diameter	
				A	B	C	
1/4	HF-251-4HB	HF304HB-4	1/4	2.81	0.81	0.99	0.26
1/4	HF-251-6HB	HF304HB-6	3/8	2.81	0.81	0.99	0.27
3/8	HF-371-6HB	HF306HB-6	3/8	3.02	0.94	1.07	0.31
3/8	HF-371-8HB	HF306HB-8	1/2	3.02	0.94	1.07	0.34

#### Push-Lok Hose Barb

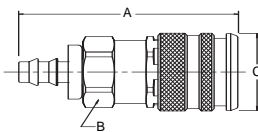

Body Size (in.)	New Part No. Brass	Old Part No. Brass	Hose I.D.	Dimensions (in.)			Wt. (LB) P/Piece
				Overall Length	Hex Size	Largest Diameter	
				A	B	C	
1/4	HF-251-4PL	HF304PL-4	1/4	2.64	0.81	0.99	0.26
1/4	HF-251-6PL	HF304PL-6	3/8	2.78	0.81	0.99	0.27
3/8	HF-371-6PL	HF306PL-6	3/8	3.02	0.94	1.07	0.33
3/8	HF-371-8PL	HF306PL-8	1/2	3.07	0.94	1.07	0.31

## Pneumatic Quick Couplings

## General Purpose – Push-To-Connect HF Series Industrial Interchange

### Heavy Duty Couplers

#### Female Pipe Thread

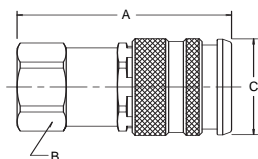

Body Size (in.)	New Part No. Steel	Old Part No. Steel	Thread Size NPSF	Dimensions (in.)			Wt. (LB) P/Piece
				Overall Length	Hex Size	Largest Diameter	
				A	B	C	
1/4	HF-251-4FP-S	HF404F-4	1/4-18	2.19	0.81	0.99	0.26
1/4	HF-251-6FP-S	HF404F-6	3/8-18	2.34	0.81	0.99	0.27
3/8	HF-371-4FP-S	HF406F-4	1/4-18	2.33	0.94	1.07	0.33
3/8	HF-371-6FP-S	HF406F-6	3/8-18	2.33	0.94	1.07	0.31
3/8	HF-371-8FP-S	HF406F-8	1/2-14	2.49	1.00	1.07	0.35

#### Male Pipe Thread

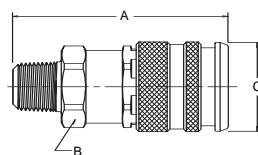

Body Size (in.)	New Part No. Steel	Old Part No. Steel	Thread Size NPTF	Dimensions (in.)			Wt. (LB) P/Piece
				Overall Length	Hex Size	Largest Diameter	
				A	B	C	
1/4	HF-251-4MP-S	HF404M-4	1/4-18	2.34	0.81	0.99	0.25
1/4	HF-251-6MP-S	HF404M-6	3/8-18	2.37	0.81	0.99	0.26
3/8	HF-371-4MP-S	HF406M-4	1/4-18	2.49	0.94	1.07	0.32
3/8	HF-371-6MP-S	HF406M-6	3/8-18	2.52	0.94	1.07	0.30
3/8	HF-371-8MP-S	HF406M-8	1/2-14	2.68	0.94	1.07	0.33

#### Standard Hose Barb

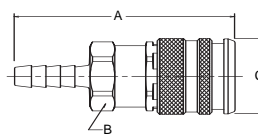

Body Size (in.)	New Part No. Steel	Old Part No. Steel	Hose I.D.	Dimensions (in.)			Wt. (LB) P/Piece
				Overall Length	Hex Size	Largest Diameter	
				A	B	C	
1/4	HF-251-4HB-S	HF404HB-4	1/4	2.81	0.81	0.99	0.26
1/4	HF-251-6HB-S	HF404HB-6	3/8	2.81	0.81	0.99	0.27
3/8	HF-371-6HB-S	HF406HB-6	3/8	3.02	0.94	1.07	0.31
3/8	HF-371-8HB-S	HF406HB-8	1/2	3.02	0.94	1.07	0.34

#### Push-Lok Hose Barb

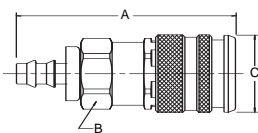

Body Size (in.)	New Part No. Steel	Old Part No. Steel	Hose I.D.	Dimensions (in.)			Wt. (LB) P/Piece
				Overall Length	Hex Size	Largest Diameter	
				A	B	C	
1/4	HF-251-4PL-S	HF404PL-4	1/4	2.64	0.81	0.99	0.26
1/4	HF-251-6PL-S	HF404PL-6	3/8	2.78	0.81	0.99	0.27
3/8	HF-371-6PL-S	HF406PL-6	3/8	3.02	0.94	1.07	0.33
3/8	HF-371-8PL-S	HF406PL-8	1/2	3.07	0.94	1.07	0.31



### Features

- Parker HA Series couplings are interchangeable with ARO's 210 series couplings. See Table of Contents.
- Push to Connect design for easy one hand operation.
- HA Series couplings utilize a tubular valve for maximum flow and a built-in sleeve guard to minimize accidental disconnect.
- The HA Series is only available in 1/4" body size.
- HA Series couplings have all brass bodies.
- Standard seal material is Nitrile. See the Coupling Selection and Ordering Information Guide at the beginning of Section A and the Fluid Compatibility Chart at the end of this catalog for optional materials.
- Other port options available – contact the division.
- Formerly the 50A Series.

### Couplers

#### Female Pipe Thread

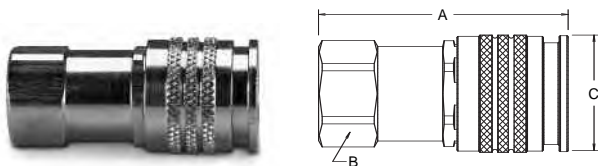

#### Male Pipe Thread

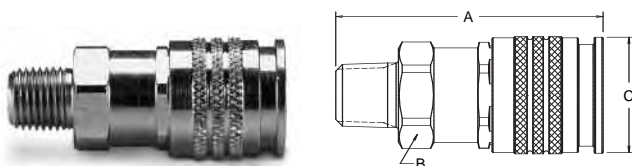

### Specifications

Body Size (in.)	1/4
Rated Pressure (psi)	300
Temperature Range (Std. seals)	-40° to +250° F
Locking Device	4 balls
Vacuum Service	<b>Not Recommended</b>

### Performance

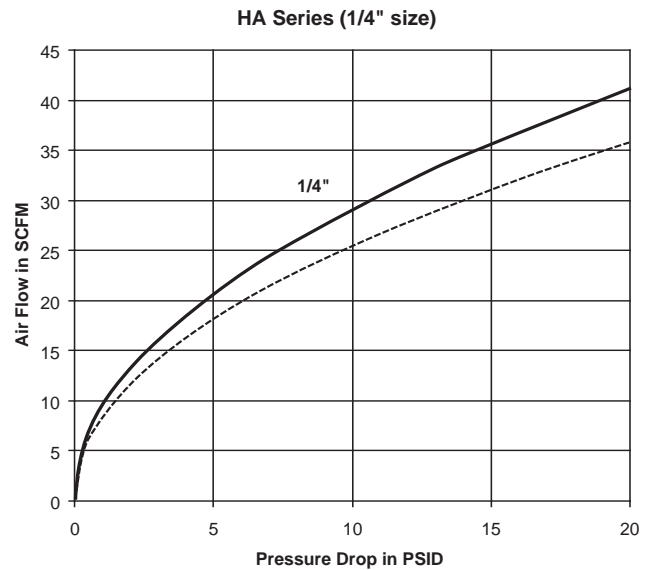

### How To Order

#### HA - 251 - 4FP - \*

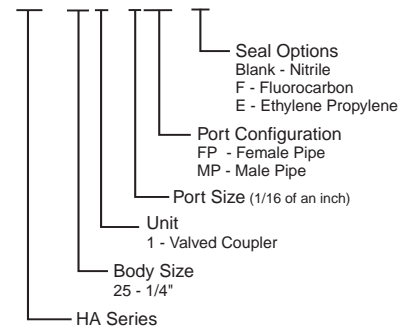

Body Size (in.)	NEW Part No. Brass	OLD Part No. Brass	Thread Size NPSF	Dimensions (in.)			Largest Diameter P/Piece	Wt. (LB)
				Overall Length	Hex Size	Hex Diameter		
1/4	HA-251-4FP	C50A02-4-4	1/4-18	2.11	0.81	1.01	0.26	

Body Size (in.)	NEW Part No. Brass	OLD Part No. Brass	Thread Size NPSF	Dimensions (in.)			Largest Diameter P/Piece	Wt. (LB)
				Overall Length	Hex Size	Hex Diameter		
1/4	HA-251-4MP	C50A01-4-4	1/4-18	2.26	0.81	1.01	0.24	

\* See page A-15 for Nipples



## Pneumatic Quick Couplings

## General Purpose – Push-To-Connect

### UC Series



### Features

- The 1/4" UC Series Coupler will accept the industrial interchange, [(MIL-C-4109F) and (ANSI/(NFPA) T3.20.14-1990)], 10 Series (Tru-Flate) and the 50 series (ARO 210) style nipples.
- The coupler features automatic push-to-connect operation, high flow machined "window valve," corrosion resistant solid brass construction and a sleeve guard which helps prevent accidental disconnects and protects the sleeve from damage.
- While the best quick coupling performance is obtained by matching like series couplers and nipples, the universal coupler permits multiple series nipples to mate with one coupler.

### Specifications

Body Size (in.)	1/4
Rated Pressure (PSI)	150
Temperature Range (Nitrile seal)	-40° to +250° F.
Locking Device	4 balls
Vacuum Service	<b>Not Recommended</b>

### How to Order

**UC - 251 - 4 FP - \***

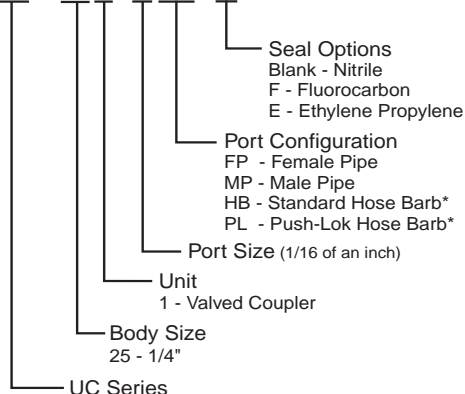

\* Contact the Division for availability

### Performance

UC Series Coupler (1/4" size)

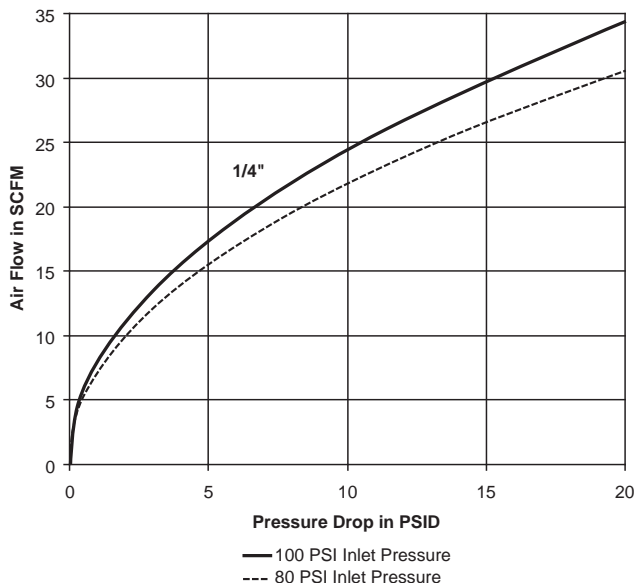

### Couplers

#### Female Pipe Thread

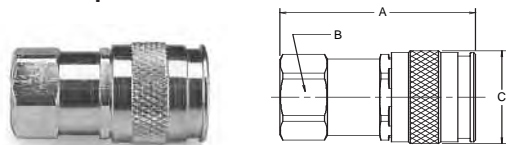

Body Size (in.)	New Part No. Brass	Old Pat No. Brass	Thread Size NPSF	Dimensions (in.)			Wt. (LB) P/Piece
				Overall Length	Hex Size	Largest Diameter	
				A	B	C	
1/4	UC-251-4FP	UC304F-4	1/4-18	2.06	0.81	0.98	0.23
1/4	UC-251-6FP	UC304F-6	3/8-18	2.21	0.81	0.98	0.23

#### Male Pipe Thread

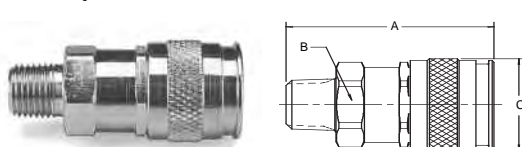

Body Size (in.)	New Part No. Brass	Old Part No. Brass	Thread Size NPTF	Dimensions (in.)			Wt. (LB) P/Piece
				Overall Length	Hex Size	Largest Diameter	
				A	B	C	
1/4	UC-251-4MP	UC304M-4	1/4-18	2.21	0.81	0.98	0.22
1/4	UC-251-6MP	UC304M-6	3/8-18	2.24	0.81	0.90	0.23

Contact the Division for Hose Barb and Push-Lok port availability



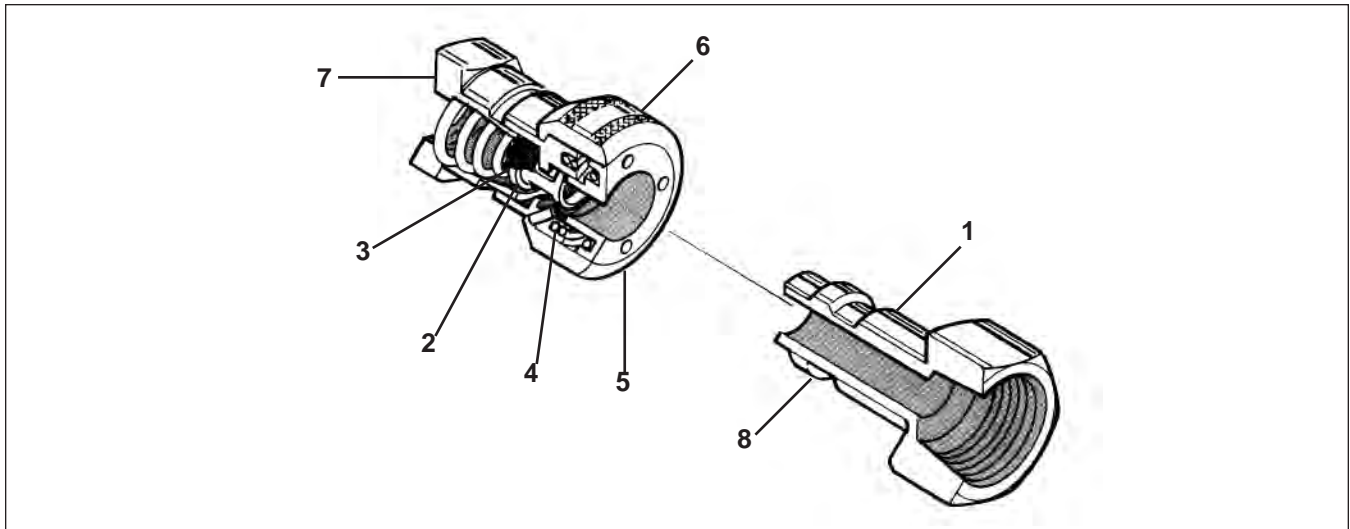

**Component Part Features**

1. Precision machining, hardened wear points\* and solid bar stock construction provide long life even in rugged applications.
2. Tubular valve with large flow passages delivers high flow with minimum pressure drop for efficient performance. The tubular design provides 360° support for both the valve seal and the mating nipple for long service life.
3. Precision molded seals form a “bubble tight” seal for reliable operation within rated working pressures. Standard seal material is Nitrile. Ethylene Propylene, Fluorocarbon and Neoprene are available as options.
4. Locking pawls (pins) constructed of stainless steel create a durable locking mechanism that provides alignment and evenly distributes loads.
5. Push-to-connect design permits one-handed connection when the coupler half is rigidly mounted.
6. Knurling on the sleeve provides a gripping surface for ease of operation.
7. Wide range of end terminations are available to meet specific needs. Parker push type couplings are available with male pipe thread, female pipe thread, standard hose barb, and Push-Lok hose barb\*\*.
8. Parker 30 Series couplings mate with industrial interchange design nipples. See Table of Contents.

\* steel nipples only

\*\* Push-Lok hose barbs are designed for use with Parker Push-Lok hose and do not require clamps.

## Pneumatic Quick Couplings

## General Purpose – Push-To-Connect 30 Series Industrial Interchange



### Features

- Parker 30 Series couplers are designed for rigid mounting that allows a simple push-to-connect operation.
- Constructed of a solid brass body and a steel valve, 30 Series couplers are noted for their high flow capability, reliability and rugged design.
- Parker 30 Series couplers accept industrial interchange nipples manufactured by Parker and other manufacturers.
- Standard seal material is Nitrile. See Ordering Information at the beginning of Section A and the Fluid Compatibility Chart at the end of this catalog for optional materials.

### Specifications

Body Size (in.)	1/4	3/8	1/2	3/4
Rated Pressure (PSI)	300	300	300	300
Temperature Range (Std. seals)*	-40° to +250° F.			
Locking Device	3 pawls	4 pawls	5 pawls	6 pawls
Vacuum Data (inches Hg)	<b>Not recommended</b>			
Disconnected (coupler only)	<b>Not recommended</b>			
Connected	27.4	27.4	27.4	27.4

\* See Coupling Selection and Ordering Guide for Optional Seals.

### Repair Kits

Body Size	Seal Material	Part No.
1/4	Nitrile	21K
1/4	Ethylene Propylene	21KW
1/4	Fluorocarbon	21KY
3/8	Nitrile	14K
3/8	Ethylene Propylene	14KW
3/8	Fluorocarbon	14KY
1/2	Nitrile	16K
1/2	Ethylene Propylene	16KW
1/2	Fluorocarbon	16KY
3/4	Nitrile	38K
3/4	Ethylene Propylene	38KW
3/4	Fluorocarbon	38KY

### How to Order Information

Available with Sleeve-Lok (See Coupler Options Section). To order, add the suffix “-SL” to part number, Example: B33-SL.

Brass valves are available for extra corrosion resistance. To specify a brass valve, add the suffix “N” to the regular part number. Example: B33N. A brass valve should be used for corrosive applications where steel parts are not suitable. Consult the factory for specific recommendations.

### Operation

Push type couplings feature one handed “automatic” connection by pushing the nipple into the coupler—provided the coupler half is firmly mounted.

The locking mechanism of Parker 30 Series couplers consists of pawls (or pins) which act directly on the sleeve, thereby causing the sleeve to automatically retract when the mating nipple is inserted.

Sleeve must be manually retracted to remove the nipple.

30 Series couplings are push type Single Shut-Off couplings.

### Performance

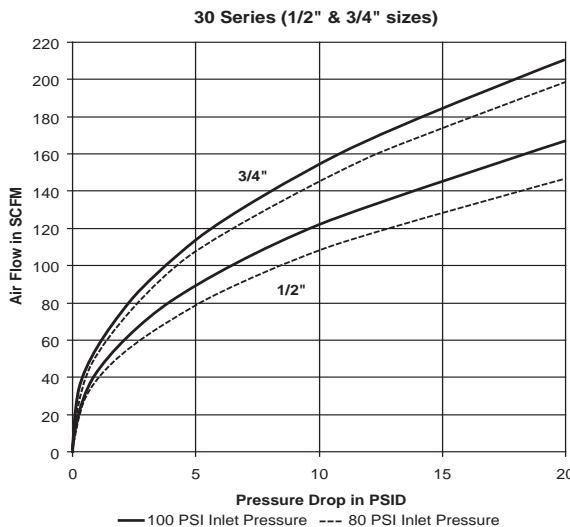
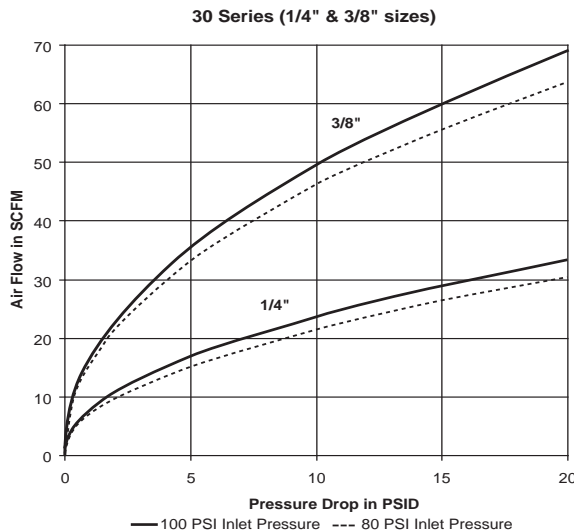

**Couplers**

**Female Pipe Thread**

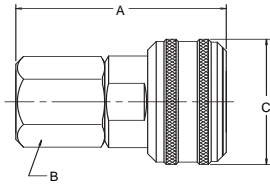

Body Size (in.)	Part No. Brass	Thread Size NPTF	Dimensions (in.)			Wt. (LB) P/Piece
			Overall Length	Hex Size	Largest Diameter	
			A	B	C	
1/4	B33A	1/8-27	1.96	0.75	1.20	0.30
1/4	B33	1/4-18	1.96	0.75	1.20	0.28
1/4	B33E	3/8-18	2.03	0.81	1.20	0.30
3/8	B35C	1/4-18	2.26	0.88	1.39	0.42
3/8	B35	3/8-18	2.33	0.88	1.39	0.42
3/8	B35F	1/2-14	2.57	1.00	1.39	0.46
1/2	B37E	3/8-18	2.76	1.00	1.52	0.56
1/2	B37	1/2-14	3.00	1.00	1.52	0.66
1/2	B37G	3/4-14	3.12	1.25	1.52	0.73
3/4	B39F	1/2-14	2.85	1.31	1.90	0.15
3/4	B39	3/4-14	2.99	1.31	1.90	1.10
3/4	B39J	1-11 1/2	3.18	1.56	1.90	1.24

**Male Pipe Thread**

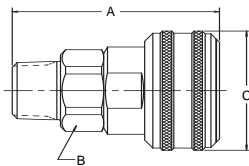

Body Size (in.)	Part No. Brass	Thread Size NPTF	Dimensions (in.)			Wt. (LB) P/Piece
			Overall Length	Hex Size	Largest Diameter	
			A	B	C	
1/4	B32A	1/8-27	2.03	0.75	1.20	0.27
1/4	B32	1/4-18	2.18	0.75	1.20	0.28
1/4	B32E	3/8-18	2.18	0.75	1.20	0.28
3/8	B34C	1/4-18	2.38	0.88	1.39	0.36
3/8	B34	3/8-18	2.44	0.88	1.39	0.39
3/8	B34F	1/2-14	2.57	0.88	1.39	0.41
1/2	B36E	3/8-18	2.92	1.00	1.52	0.58
1/2	B36	1/2-14	3.09	1.00	1.52	0.61
1/2	B36G	3/4-14	3.12	1.13	1.52	0.67
3/4	B38	3/4-14	2.95	1.31	1.90	0.91
3/4	B38J	1-11 1/2	3.12	1.31	1.90	0.99

## Pneumatic Quick Couplings

## General Purpose – Push-To-Connect 30 Series Industrial Interchange

### Couplers

#### Standard Hose Barb

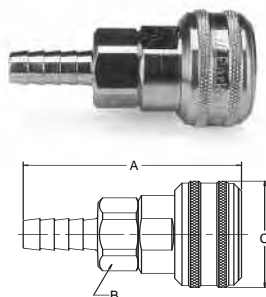

Body Size (in.)	Part No. Brass	Hose I.D.	Dimensions (in.)			Wt. (LB) P/Piece
			Overall Length	Hex Size	Largest Diameter	
			A	B	C	
1/4	B30-3B	1/4	2.62	0.75	1.20	0.27
1/4	B30-4B	5/16	2.62	0.75	1.20	0.27
1/4	B30-5B	3/8	2.62	0.75	1.20	0.28
3/8	B34-5B	3/8	2.85	0.88	1.39	0.39
3/8	B34-6B	1/2	2.85	0.88	1.39	0.41
1/2	B36-6B	1/2	3.33	1.00	1.52	0.59
1/2	B36-7B	3/4	3.86	1.00	1.52	0.65
3/4	B38-7B	3/4	3.69	1.31	1.90	0.93
3/4	B38-8B	1	3.93	1.31	1.90	1.03

#### Push-Lok Hose Barb\*

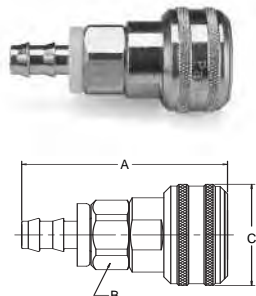

Body Size (in.)	Part No. Brass	Hose I.D.	Dimensions (in.)			Wt. (LB) P/Piece
			Overall Length	Hex Size	Largest Diameter	
			A	B	C	
1/4	B30-3BP	1/4	2.45	0.75	1.20	0.27
1/4	B30-5BP	3/8	2.60	0.75	1.20	0.29
3/8	B34-5BP	3/8	2.82	0.88	1.39	0.40
1/2	B36-6BP	1/2	3.46	1.00	1.52	0.56

\* Push-Lok hose barbs are designed for use with Parker Push-Lok hose and do not require clamps.



### Features

- Push-to-Connect design for easy one hand operation.
- A variety of port configurations are available to meet specific needs.
- Standard Seals are Nitrile.
- Zinc bodies with Chromium-6 Free plated steel sleeves and nipples.
- Interchanges with Schrader Twist-Lock style couplings.

### Operation

- Engineered for speedy coupling and uncoupling. To lock – push in; to unlock – give the coupler sleeve a 1/8 turn. Designed to protect against accidental uncoupling.

### How To Order

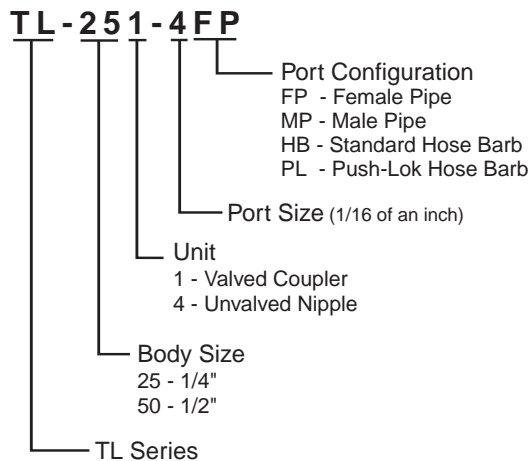

### Specification

Body Size (in.)	1/4	1/2
Rated Pressure (PSI)	300	300
Temperature Range (Nitrile seal)	-40° F to +250° F.	
Locking Device	CAM	
Vacuum Service	Not Recommended	

### Performance

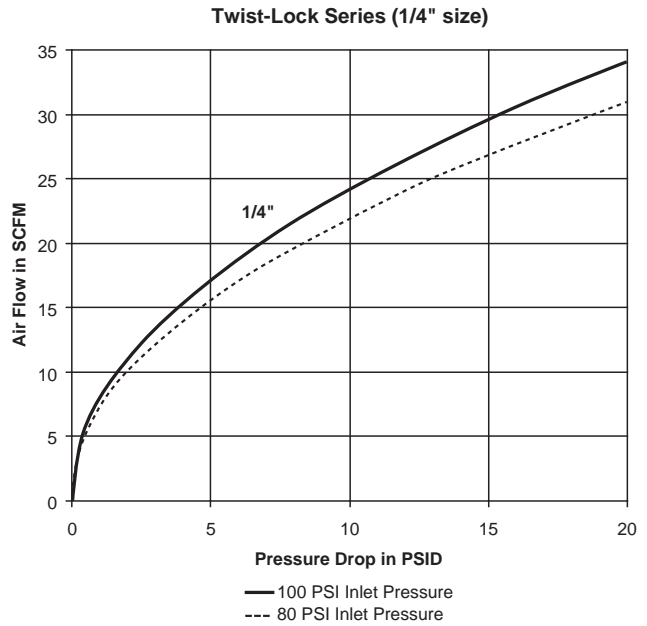

## Pneumatic Quick Couplings

## General Purpose – Push-To-Connect Twist-Lock

### Couplers

#### Female Thread

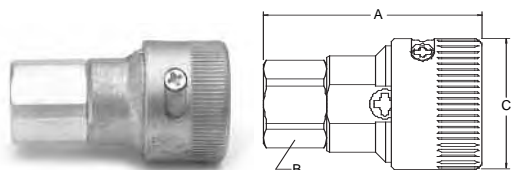

Body Size (in.)	NEW Part No. Steel	OLD Part No. Steel	Thread Size NPT	Dimensions (in.)			Wt. (LB) P/Piece
				Overall Length	Hex Size	Largest Diameter	
				A	B	C	
1/4	TL-251-4FP	8052-0319	1/4-18	2.01	0.75	1.12	0.21
1/2	TL-501-6FP	1095-0040	3/8-18	2.55	1.13	1.50	0.44
1/2	TL-501-8FP	1461-0070	1/2-14	2.78	1.13	1.50	0.44
1/2	TL-501-12FP	1462-0040	3/4-14	2.91	1.13	1.50	0.44

#### Male Thread

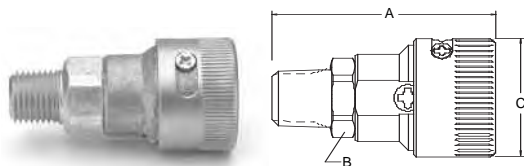

Body Size (in.)	NEW Part No. Steel	OLD Part No. Steel	Thread Size NPT	Dimensions (in.)			Wt. (LB) P/Piece
				Overall Length	Hex Size	Largest Diameter	
				A	B	C	
1/4	TL-251-4MP	3060-0109	1/4-18	2.23	0.75	1.12	0.21
1/4	TL-251-6MP	3061-0109	3/8-18	2.26	0.75	1.12	0.22
1/2	TL-501-6MP	3080-0020	3/8-18	2.71	1.13	1.50	0.39
1/2	TL-501-8MP	3081-0020	1/2-14	2.88	1.13	1.50	0.40

### Nipples

#### Female Thread

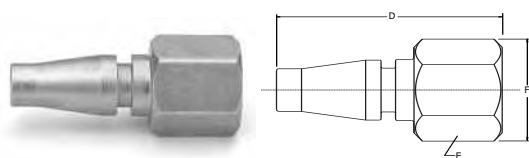

Body Size (in.)	NEW Part No. Steel	OLD Part No. Steel	Thread Size NPT	Dimensions (in.)			Wt. (LB) P/Piece
				Overall Length	Hex Size	Largest Diameter	
				D	E	F	
1/4	TL-254-2FP	2047-0010	1/8-27	1.53	0.56	0.65	0.04
1/4	TL-254-4FP	8278-0050	1/4-18	1.81	0.69	.79	0.07
1/2	TL-504-4FP	1261-0020	1/4-18	1.68	0.69	0.80	0.14
1/2	TL-504-6FP	1096-0010	3/8-18	1.84	0.88	1.01	0.14

#### Male Thread

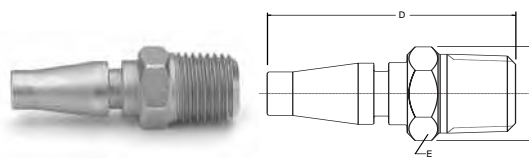

Body Size (in.)	NEW Part No. Steel	OLD Part No. Steel	Thread Size NPT	Dimensions (in.)			Wt. (LB) P/Piece
				Overall Length	Hex Size	Largest Diameter	
				D	E	F	
1/4	TL-254-2MP	8051-0010	1/8-27	1.65	0.56	0.65	0.05
1/4	TL-254-4MP	8050-0110	1/4-18	1.75	0.56	0.65	0.05
1/2	TL-504-4MP	8624-0070	1/4-18	1.87	0.69	0.80	0.12
1/2	TL-504-6MP	1095-0020	3/8-18	1.93	0.69	0.80	0.12
1/2	TL-504-8MP	1461-0050	1/2-14	2.16	0.88	1.01	0.13
1/2	TL-504-12MP	1462-0100	3/4-14	2.16	1.06	1.22	0.14

#### Standard Hose Barb

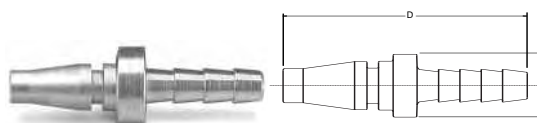

Body Size (in.)	NEW Part No. Steel	OLD Part No. Steel	Thread Size NPT	Dimensions (in.)		Wt. (LB) P/Piece
				Overall Length	Largest Diameter	
				D	F	
1/4	TL-254-4HB	8787-0040	1/4	1.83	0.50	0.04
1/4	TL-254-6HB	8788-0030	3/8	1.83	0.50	0.06
1/2	TL-504-4HB	2123-0030	1/4	2.31	0.80	0.10
1/2	TL-504-6HB	1097-0010	3/8	2.28	0.69	0.11
1/2	TL-504-8HB	1098-0010	1/2	2.28	0.81	0.12



### Features

- Standard style Tool-Mate couplers are lightweight, easy to operate, and non-marring with easy, push-to-connect action.
- Couplers are constructed of Polyamide material; springs, balls, and pins are stainless steel; and locking fingers are made of polyacetate.
- PBH Tool-Mate Series is built to the Industrial Interchange profile identifiable with a Yellow ring around the body.
- PER Tool-Mate Series is designed to use with Parker's high flow RF Series nipples and is identifiable with a Green ring around the body.
- Grey body designates standard non-venting style coupler.

### Operation

- Push-to-Connect design for easy one hand operation.
- Pull in the direction of the arrow indicated on the body of the coupler to release the nipple.

### Specifications

Body Size	1/4"	3/8"
Rated Pressure	300	300
Temperature Range (°F)	0 to 160	0 to 160
Vacuum Service	Not Recommended	

### How To Order

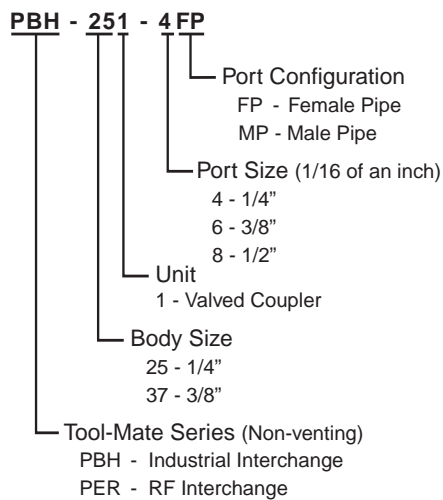

### Performance

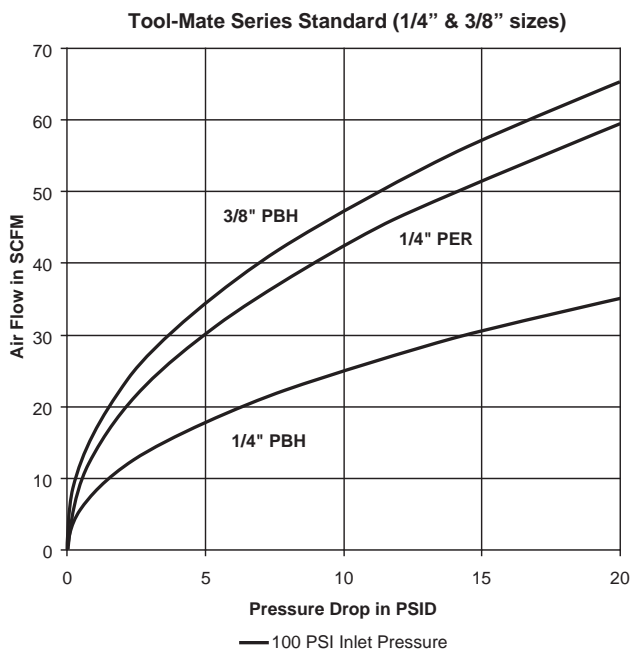

## Pneumatic Quick Couplings

## Special Purpose – Standard - Non Marring Tool-Mate Series

### Industrial Interchange

#### Female Pipe Thread

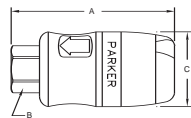

Body Size (in.)	Part No.	Thread Size NPTF	Overall Length	Hex Size	Largest Diameter	Wt. (LB) P/Piece
			A	B	C	
1/4"	PBH-251-4FP	1/4-18	2.60	0.67	1.19	0.13
1/4"	PBH-251-6FP	3/8-18	2.67	0.91	1.19	0.15
3/8"	PBH-371-4FP	1/4-18	2.95	0.67	1.38	0.21
3/8"	PBH-371-6FP	3/8-18	2.95	0.83	1.38	0.20
3/8"	PBH-371-8FP	1/2-14	3.17	0.99	1.38	0.22

#### Male Pipe Thread

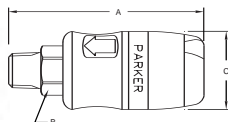

Body Size (in.)	Part No.	Thread Size NPTF	Overall Length	Hex Size	Largest Diameter	Wt. (LB) P/Piece
			A	B	C	
1/4"	PBH-251-4MP	1/4-18	2.97	0.67	1.19	0.14
1/4"	PBH-251-6MP	3/8-18	2.99	0.91	1.19	0.19
3/8"	PBH-371-4MP	1/4-18	3.39	0.83	1.38	0.23
3/8"	PBH-371-6MP	3/8-18	3.39	0.83	1.38	0.23

### RF Interchange

#### Female Pipe Thread

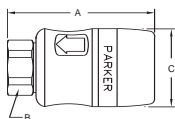

Body Size (in.)	Part No.	Thread Size NPTF	Overall Length	Hex Size	Largest Diameter	Wt. (LB) P/Piece
			A	B	C	
1/4"	PER-251-4FP	1/4-18	2.83	0.83	1.25	0.17
1/4"	PER-251-6FP	3/8-18	2.83	0.83	1.25	0.15

#### Male Pipe Thread

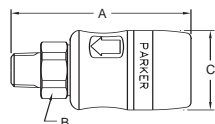

Body Size (in.)	Part No.	Thread Size NPTF	Overall Length	Hex Size	Largest Diameter	Wt. (LB) P/Piece
			A	B	C	
1/4"	PER-251-4MP	1/4-18	2.36	0.83	1.25	0.19
1/4"	PER-251-6MP	3/8-18	2.40	0.83	1.25	0.18

## Pneumatic Quick Couplings

## Special Purpose – Exhaust - Non Marring Tool-Mate Series



### Features

- Exhaust style Tool-Mate couplers are lightweight, easy to operate, and non-marring with easy, push-to-connect action and one-handed disconnection.
- Couplers are constructed of black Polyamide material; springs, balls, and pins are stainless steel in the PES series and 1/2" PBS series; and locking fingers in the PBS series are made of polyacetate. End ports are galvanized steel.
- PBS Tool-Mate Series is built to the Industrial Interchange profile identifiable with a Yellow ring around the body.
- PES Tool-Mate Series is designed for use with high flow RF Series nipples and is identifiable with a Green ring around the body.
- Exhaust style Tool-Mate couplers meet the ISO 4414 specification to allow trapped air pressure to be vented prior to disconnection.
- Black body designates exhaust style coupler.

### Specifications

Body Size	1/4"	3/8"	1/2"
Rated Pressure	300	300	300
Temperature Range (°F)	0 to 160	0 to 160	0 to 160
Vacuum Service	Not Recommended		

### Operation

- Push-to-Connect design for easy one hand operation.
- Pull the body in the direction of the arrow marked 1, this will safely vent the downstream pressure.
- Push the body in the direction of arrow 2 to disconnect at 0 pressure.

### How To Order

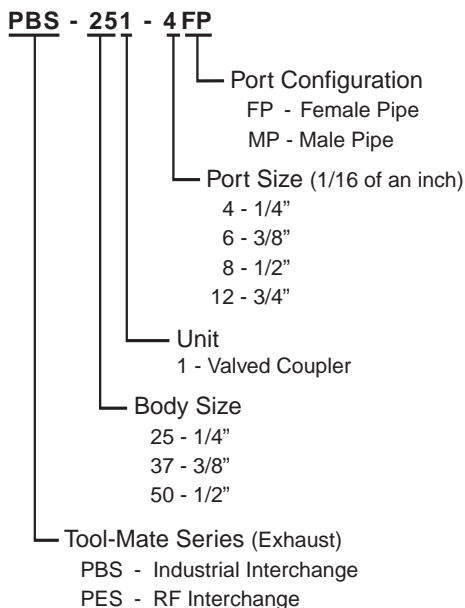

### Performance

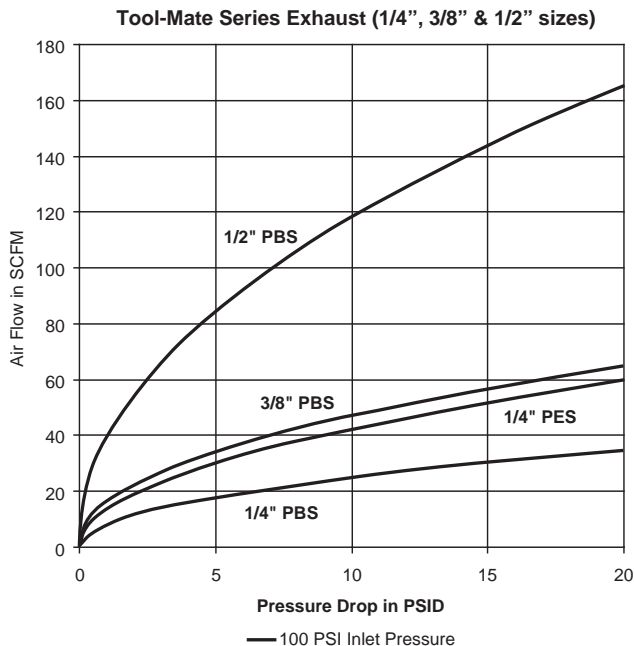

## Pneumatic Quick Couplings

## Special Purpose – Exhaust - Non Marring Tool-Mate Series

### Exhaust Industrial Interchange

#### Female Pipe Thread

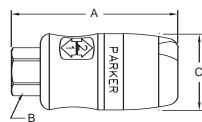

Body Size (in.)	Part No	Thread Size NPTF	Overall Length	Hex Size	Largest Diameter	Wt. (LB) P/Piece
			A	B	C	
1/4"	PBS-251-4FP	1/4-18	2.60	0.67	1.19	0.13
1/4"	PBS-251-6FP	3/8-18	2.67	0.91	1.19	0.15
3/8"	PBS-371-6FP	3/8-18	2.95	0.82	1.38	0.20
3/8"	PBS-371-8FP	1/2-14	3.17	0.99	1.38	0.22
1/2"	PBS-501-6FP	3/8-18	3.25	1.18	1.62	0.50
1/2"	PBS-501-8FP	1/2-14	3.36	1.18	1.62	0.50
1/2"	PBS-501-12FP	3/4-14	3.66	1.18	1.62	0.50

#### Male Pipe Thread

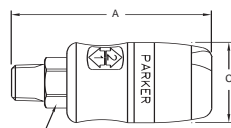

Body Size (in.)	Part No.	Thread Size NPTF	Overall Length	Hex Size	Largest Diameter	Wt. (LB) P/Piece
			A	B	C	
1/4"	PBS-251-4MP	1/4-18	2.97	0.67	1.19	0.14
1/4"	PBS-251-6MP	3/8-18	2.99	0.91	1.19	0.19
3/8"	PBS-371-6MP	3/8-18	3.39	0.82	1.38	0.23
3/8"	PBS-371-8MP	1/2-18	3.39	0.91	1.38	0.28
1/2"	PBS-501-8MP	1/2-18	3.70	1.18	1.62	0.50

### Exhaust RF Interchange

#### Female Pipe Thread

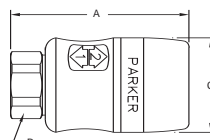

Body Size (in.)	Part No.	Thread Size NPTF	Overall Length	Hex Size	Largest Diameter	Wt. (LB) P/Piece
			A	B	C	
1/4"	PES-251-6FP	3/8-18	2.83	0.83	1.25	0.15

#### Male Pipe Thread

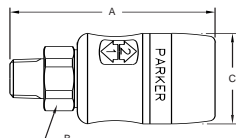

Body Size (in.)	Part No.	Thread Size NPTF	Overall Length	Hex Size	Largest Diameter	Wt. (LB) P/Piece
			A	B	C	
1/4"	PES-251-4MP	1/4-18	2.36	0.83	1.25	0.19

## Pneumatic Quick Couplings

## Special Purpose – Exhaust - Steel E-z-mate Series Industrial Interchange



### Operation

Parker E-z-mate couplings combine push-to-connect, exhaust-style action with a self-locking valve sleeve to guard against accidental disconnection. Simply follow the direction of the On-Off arrow stamped on the yellow chromate valve sleeve. It's that easy.

To connect, push the nipple into the coupler. The black locking sleeve automatically slides forward securely locking the nipple in place. No air is allowed to flow through the coupling at this point. The yellow chromate valve sleeve is then rotated clockwise (when viewed from the coupler port end) to open flow and automatically engage the sleeve-lock mechanism.

To disconnect, rotate the valve sleeve counter clockwise (when viewed from the coupler end). The flow of air through the coupling will be shut off and all downstream air is vented to the atmosphere. The locking sleeve may now be retracted and the nipple removed. Lubricate sleeve as part of periodic maintenance to coupler.

### Specifications

Body Size (in.)	1/4	3/8	1/2	3/4
Rated Pressure (PSI)	300	300	300	300
Temperature Range (std seals)	-40° to +250° F.			
Locking Device	4 balls	4 balls	6 balls	8 balls
Force required to Connect (lbs)	Less than 10			
Vacuum Service	<b>Not recommended</b>			

### How To Order

#### EZ - 251 - 4 FP

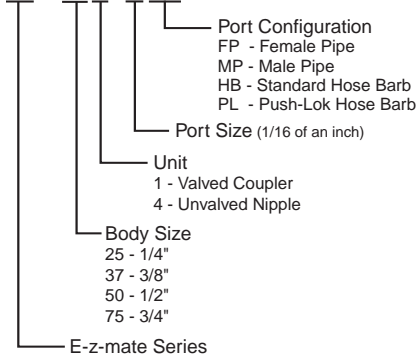

### Features

- Parker's E-z-mate is an exhaust type coupler that is designed to exhaust air pressure prior to the disconnection process.
- The valve sleeve acts as an integral shut-off valve that allows connection and disconnection at zero pressure. When the sleeve is moved to shut off air flow, it automatically vents downstream allowing for disconnection at zero pressure and eliminating the risk of "hose whip."
- Meets ISO 4414 requirements for a controlled pressure release system.
- Built-in sleeve-lok mechanically locks the valve sleeve to help prevent accidental disconnects.
- Proven ball locking mechanism evenly distributes load to resist wear and provide positive connections. The ball locking mechanism also provides accurate alignment and allows a swiveling action to reduce hose torque.
- O-ring interface seal assures "bubble tight" seal and long service life.
- E-z-mate Series couplers use industrial interchange nipples.
- Brass versions available. Contact the division for availability.

### Performance

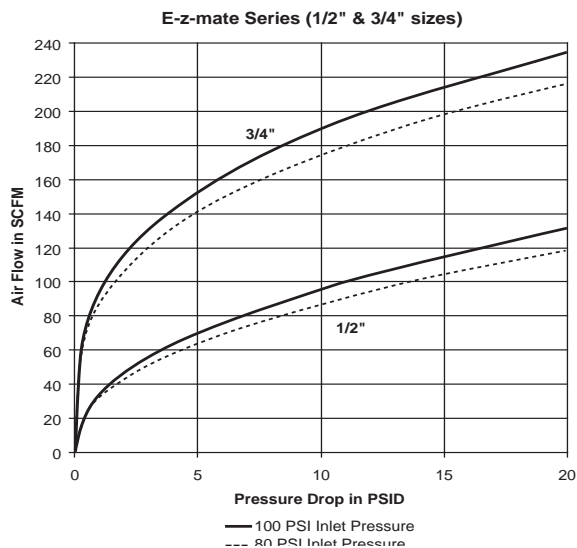
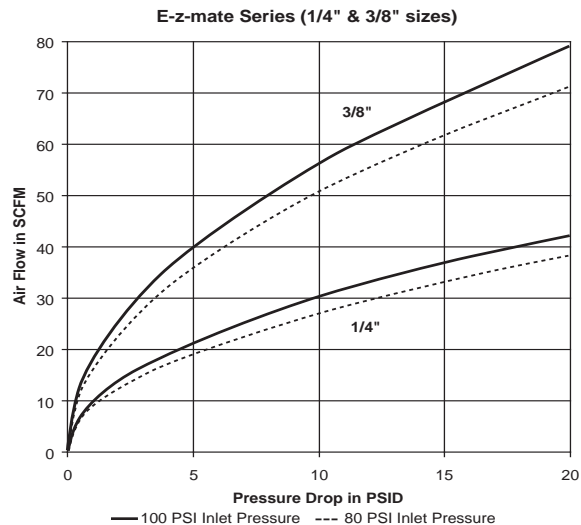

## Pneumatic Quick Couplings

### Special Purpose – Exhaust - Steel E-z-mate Series Industrial Interchange

#### Couplers

##### Female Pipe Thread

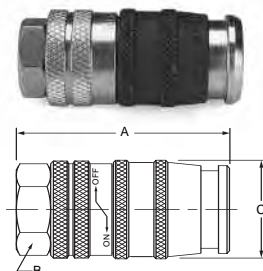

Body Size (in.)	New Part No. Steel	Old Part No. Steel	Thread Size NPTF	Dimensions (in.)			Wt. (LB) P/Piece
				Overall Length	Hex Size	Largest Diameter	
				A	B	C	
1/4	EZ-251-4FP	EZ304F-4T	1/4-18	2.25	0.75	1.00	0.25
1/4	EZ-251-6FP	EZ304F-6T	3/8-18	2.68	0.88	1.01	0.29
3/8	EZ-371-6FP	EZ306F-6T	3/8-18	2.53	0.88	1.18	0.38
3/8	EZ-371-8FP	EZ306F-8T	1/2-14	3.00	1.12	1.30	0.50
1/2	EZ-501-8FP	EZ308F-8T	1/2-14	3.01	1.12	1.38	0.65
1/2	EZ-501-12FP	EZ308F-12T	3/4-14	3.44	1.38	1.59	0.70
3/4	EZ-751-12FP	EZ312F-12T	3/4-14	3.01	1.38	1.57	0.76
3/4	EZ-751-16FP	EZ312F-16T	1-11 1/2	3.52	1.56	1.80	0.92

##### Male Pipe Thread

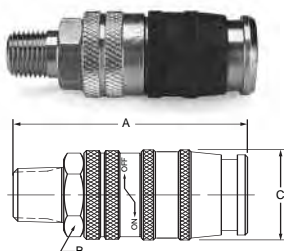

Body Size (in.)	New Part No. Steel	Part No. Steel	Thread Size NPTF	Dimensions (in.)			Wt. (LB) P/Piece
				Overall Length	Hex Size	Largest Diameter	
				A	B	C	
1/4	EZ-251-4MP	EZ304M-4T	1/4-18	2.85	0.75	1.00	0.30
1/4	EZ-251-6MP	EZ304M-6T	3/8-18	2.87	0.75	1.00	0.31
3/8	EZ-371-6MP	EZ306M-6T	3/8-18	3.10	0.88	1.18	0.44
1/2	EZ-501-8MP	EZ308M-8T	1/2-14	3.62	1.12	1.38	0.73
3/4	EZ-751-12MP	EZ312M-12T	3/4-14	4.04	1.38	1.57	0.90

##### Standard Hose Barb

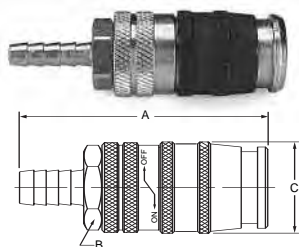

Body Size (in.)	New Part No. Steel	Old Part No. Steel	Hose I.D.	Dimensions (in.)			Wt. (LB) P/Piece
				Overall Length	Hex Size	Largest Diameter	
				A	B	C	
1/4	EZ-251-4HB	EZ304HB-4T	1/4	3.20	0.75	1.00	0.28
1/4	EZ-251-6HB	EZ304HB-6T	3/8	3.20	0.75	1.00	0.29
3/8	EZ-371-6HB	EZ306HB-6T	3/8	3.43	0.88	1.18	0.42
1/2	EZ-501-8HB	EZ308HB-8T	1/2	4.06	1.12	1.40	0.70

##### Push-Lok Hose Barb\*

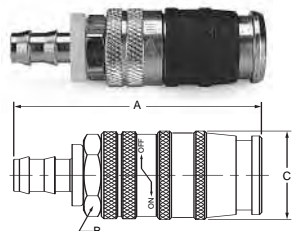

Body Size (in.)	New Part No. Steel	Old Part No. Steel	Hose I.D.	Dimensions (in.)			Wt. (LB) P/Piece
				Overall Length	Hex Size	Largest Diameter	
				A	B	C	
1/4	EZ-251-4PL	EZ304PL-4T	1/4	3.03	0.75	1.00	0.28
1/4	EZ-251-6PL	EZ304PL-6T	3/8	3.18	0.75	1.00	0.29
3/8	EZ-371-6PL	EZ306PL-6T	3/8	3.38	0.88	1.18	0.42
1/2	EZ-501-8PL	EZ308PL-8T	1/2	3.91	1.12	1.38	0.70

\* Push-Lok hose barbs are designed for use with Parker Push-Lok hose and do not require clamps.

**Note:** See Table of Contents for Industrial Interchange nipples used with E-z-mate Series couplers.

## Pneumatic Quick Couplings

## Accessories

### Blow Guns (Controlled Pressure)

#### Features

- Parker Controlled Pressure Blow Guns meet OSHA requirements (section 29 CFR 1910.242 paragraph b), and directive #100-1. "Compressed air shall not be used for cleaning purposes except where reduced to less than 30 psi, and then only with effective chip guarding and personal protective equipment."
- Parker Controlled Pressure Blow Guns have a black epoxy coated zinc body and vented nozzles to prevent pressure build-up when dead ending occurs up to 150 psi.



#### Description

**410-S** – Parker Controlled Pressure Blow Guns features thumb lever valve actuator and brass nozzle. Inlet port is 1/4" NPT.

#### Specifications

Part No.	Maximum Pressure	Wt. (LB) P/Piece
410-S	150 PSI.	0.50
410-SV	150 PSI	0.53
415-S	150 PSI	0.48



**410-SV** – Parker Venturi Nozzle Controlled Pressure Blow Gun with thumb lever valve and large venturi side ports for high volume flow. Inlet port is 1/4" NPT.



**415-S** – Parker Controlled Pressure Blow Guns features push button valve actuator and brass nozzle. Inlet port is 1/4" NPT.



#### Part No. 400-S-TIP

Blow Gun  
Replacement Tip

## Accessories

### Blow Guns (Full Pressure)

The following Parker Blow Guns must have a pressure regulator setting below 30 psi to conform to OSHA safety requirements 29 CFR 1910.242 Paragraph b.

#### Description

**410** – Parker two way thumb lever valve has a zinc body with 1/4" NPT inlet and 1/8" NPSF outlet.

#### Specifications

Part No.	Maximum Pressure	Wt. (LB) P/Piece
410	150 PSI	0.48
410-N	150 PSI	0.51
415-N	150 PSI	0.49

**Note:** Standard Gun without nozzle.



**410-N** – Parker thumb lever style Blow Gun features a zinc body, brass nozzle, and 1/4" NPT female inlet.



**415-N** – Parker Blow Gun features a push button style actuator, zinc body with a brass nozzle and 1/4" NPT female inlet.



### Description

Made from impact resistant plastic, BG Series blow guns are durable and versatile. Extended nozzles allow air to be directed where it is required. The pistol grip trigger allows greater control over the amount of air delivered. Combined, these two features provide superior performance in a light weight, ergonomically designed package.

Nozzles are available in short and extended versions and most models meet OSHA directives on the use of compressed air for cleaning purposes. OSHA directive #100-1 states that "when dead ending occurs a static pressure at the main orifice shall not exceed 30 psi." For those blow guns that do not meet this requirement, OSHA requires that "compressed air shall not be used for cleaning purposes except where reduced to less than 30 psi, and then only with effective chip guarding and personal protective equipment" (section 29 CFR 1910.242 paragraph b). Please refer to the blow gun descriptions below for compatibility with OSHA directive #100-1.

Nozzle configurations are designed for maximum flexibility. Applications with special requirements may find the BG443-NBL with a 1/8" NPT fitting convenient for adapting existing nozzles or extra-long extensions. For information on specials or made-to-order blow gun nozzles, please contact the Quick Coupling Division.



Part Number	Nozzle	Meets OSHA Requirements
BG441-NBL	Extended	No



Part Number	Nozzle	Meets OSHA Requirements
BG442-SBL	Extended	Yes



Part Number	Nozzle	Meets OSHA Requirements
BG443-NBL	1/8" Female NPT	No



Part Number	Nozzle	Meets OSHA Requirements
BG444-SBL	Vortec	Yes

### Features

- Easy to control variable flow pistol grip trigger.
- Nozzles available that meet OSHA requirements.
- Lightweight ergonomical design.
- Bodies are constructed of impact resistant plastic.

### Specifications

Rated Pressure (PSI)	175 psi
Temperature Range	to 120° F
Inlet Port	1/4" NPTF

### How to Order

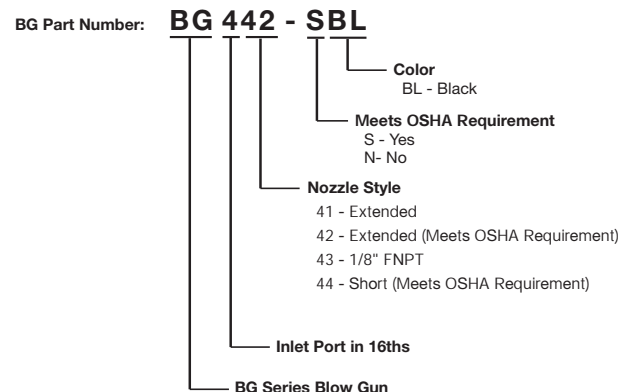

## Pneumatic Quick Couplings

## Accessories Two-Way Valves

### Features

- Parker two-way valves are designed for use in air or liquid service.
- Bodies are constructed of black molded polypropylene.
- The valve cartridge components are machined from brass and stainless steel for corrosion resistance and long life.
- Nitrile stem seals are standard. Add suffix Y for optional fluorocarbon seal. Consult factory for price and delivery.

### Specifications

<b>Rated Pressure (PSI)</b>	175 @ 70° F	120 @ 180° F
<b>Temperature Range</b>	-20° to 180° F	



### Description

**P410B** – Two way valve with forward positioned lever handle. Inlet and outlet ports are 1/4" NPT.



**P415B** – Two way valve features push button style valve actuator. Inlet and outlet ports are 1/4" NPT.



**P420B** – Reverse oriented lever handle is used in carpet cleaning applications which utilize tube mounted valves. Inlet and outlet ports are 1/4".